

QUT Digital Repository:  
<http://eprints.qut.edu.au/>



Chakrabarti, Saikat and Kyriakides, Elias and Bi, Tianshu and Cai, Deyu and Terzija, Vladimir (2009) *Measurements get together*. IEEE power & energy magazine, 7(1). pp. 41-49.

© Copyright 2009 IEEE

# Measurements Get Together

Synchronized Measurement Technology Has the Potential of Becoming the Backbone for Real-Time Monitoring

EVERYDAY LIFE RELIES HEAVILY ON THE reliable operation and intelligent management of critical infrastructures, such as electric power systems, telecommunication networks, and water distribution networks. Designing, monitoring and controlling such systems is becoming increasingly more challenging as a consequence of the steady growth of their size, complexity, level of uncertainty, unpredictable behavior, and interactions. These critical infrastructures are susceptible to natural disasters, frequent failures, and malicious attacks. At the epicenter of the well-being and prosperity of society lie the electric power systems. The secure and reliable operation of modern power systems is an increasingly challenging task due to the ever-increasing demand for electricity, the growing number of interconnections, penetration of variable renewable energy sources, and deregulated energy market conditions. Power companies in different parts of the world are therefore feeling the need for a real-time wide area monitoring, protection, and control (WAMPAC) system. Synchronized measurement technology (SMT) has the potential of becoming the backbone of this system. The major advantages of using SMT are that 1) the measurements from widely dispersed locations can

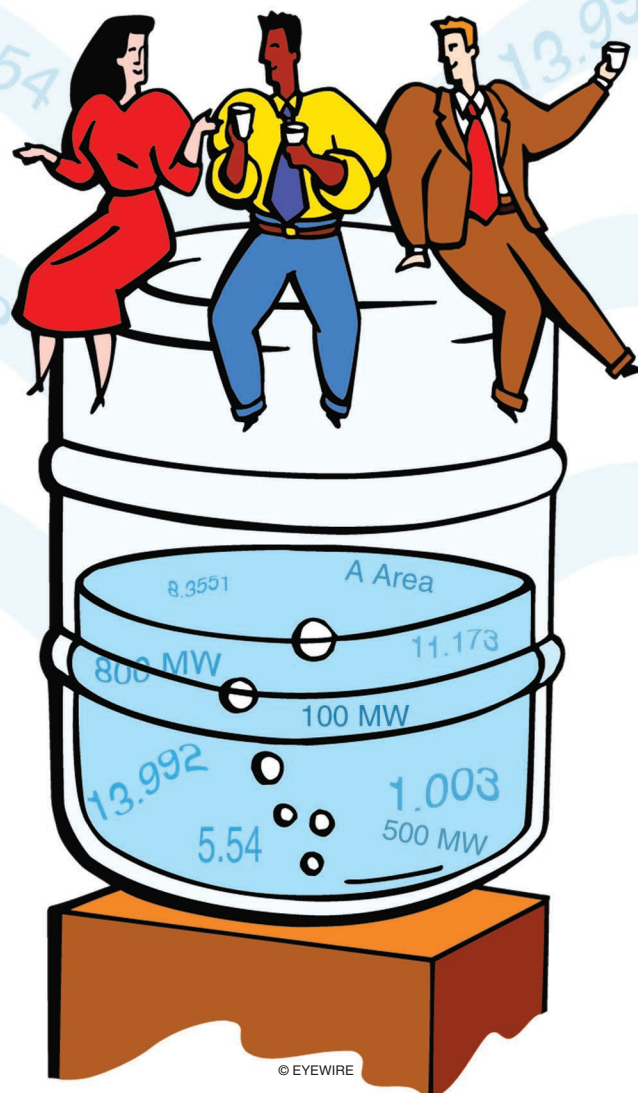

**Saikat Chakrabarti,  
Elias Kyriakides,  
Tianshu Bi, Deyu Cai,  
and Vladimir Terzija**

**table 1. PMU deployment in different parts of the world.**

PMU Applications	North America	Europe	China	India	Brazil	Russia
Post-disturbance analysis	✓	✓	✓	P	T	✓
Stability monitoring	✓	✓	✓	P	P	✓
Thermal overload monitoring	✓	✓	✓	P	P	✓
Power system restoration	✓	✓	✓	P	P	P
Model validation	✓	✓	✓	P	T	✓
State estimation	P	P	P	P	P	P
Real-time control	T	T	T	P	P	P
Adaptive protection	P	P	P	P	P	P
Wide area stabilizer	T	T	T	P	P	P

T = Testing phase; P = Planning stage

be synchronized with respect to a global positioning system (GPS) clock, 2) voltage phase angles can be measured directly, which was so far technically infeasible, and 3) the accuracy and speed of energy management system (EMS) applications (e.g., state estimation) increases manifold.

At present, phasor measurement units (PMUs) are the most widely used SMT-based device for power system applications. The first prototype of the PMU was developed and tested in Virginia Tech in the early 1980s. The first commercial unit, the Macrodyne 1690 was developed in 1991. In the late 1990s, Bonneville Power Administration (BPA) developed a wide area measurement system (WAMS), which initiated the usage of PMUs for large-scale power systems. Figure 1 shows the block diagram of the PMU, originally developed at Virginia Tech. PMU technology is maturing rapidly, and a number of vendors are offering equipment either with phasor measurement facilities alone (standalone PMUs) or with additional protective relaying features (integrated PMUs). Various compliance levels and performance metrics for PMUs are prescribed in the IEEE standard C37.118-2005 for synchrophasors for power systems. A PMU, when placed at a bus, can provide a highly accurate measurement of the voltage phasor at that bus, as well as the current phasors through the incident transmission lines (depending on the available measurement channels). Modern PMUs have some other features, like frequency measurement, measurement of derived quantities (e.g., power components, power quality related indicators, etc.), and monitoring of the status of substation apparatus.

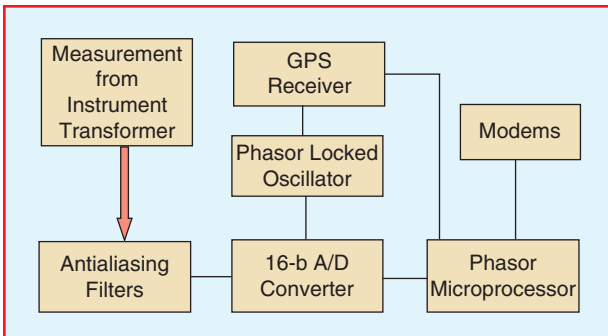

**figure 1.** Basic architecture of a PMU.

## SMT Deployment in Different Parts of the World

PMUs are increasingly being used in different parts of the world as the major technology enabler of the WAMPAC system. The general objective of these PMU installation activities is to eventually make a transition from the conventional supervisory control and data acquisition (SCADA)-based measurement system to a more advanced measurement system that will utilize synchronized measurements from geographically distant locations and increase the situational awareness by monitoring a wide area of the power system in real time. This will help in observing the dynamics of the system and taking necessary protection and control actions in real time. In various countries, PMUs or relays with PMU capabilities are being installed on a test basis by academic or utility researchers to perform case studies, measurements, and analyses of the capabilities of synchronized measurement devices. These devices are typically installed on adjacent buses and usually their measurements are not used by the system operator. However, synchronized measurement devices are being deployed in certain parts of the world and used in applications such as system monitoring, post disturbance analysis, monitoring of interarea oscillations, and system modeling. A brief overview of the existing PMU deployment in some of the major world economies is presented next. As the list of applications is dynamic as more and more PMU devices are being deployed, the list below is not exhaustive. Table 1 summarizes the major PMU-related activities in different parts of the world.

### North America

More than 200 PMUs are installed and more are in the pipeline under the North American Synchrophasor Initiative (NASPI). A number of utilities in the United States, Canada, and Mexico are involved in this project. The short-term (one to three years) goal of this project involves angle/frequency monitoring, post-mortem analysis, voltage stability monitoring, thermal overload monitoring, improved state estimation, steady-state model benchmarking, applications related to distributed generation, and power system restoration. The medium-term (three to five years) goal involves the use of SMT for congestion management, dynamic model

## SMT is a relatively new technology and has received significant attention from power system researchers in recent years.

benchmarking, and planned power system separation. The long-term (beyond five years) objective of the project is to use SMT for state estimation (using PMU measurements only), real-time control, adaptive protection, and implementation of wide area power system stabilizers. Innovative techniques for real-time data analysis and utilization of PMU measurements for better monitoring of stability of the system are being developed in the participating organizations.

### **Europe**

A number of WAMSs are in operation in Central and Western Europe. The utilities in the Nordic countries are already using PMUs extensively. Countries in Central Europe have started using PMUs and are currently exchanging synchronized measurements for better monitoring of the system. At present, the synchronized data are mainly used for post-disturbance analysis and improved system modeling. However, the major focus is on developing systematic ways for monitoring and damping of interarea oscillations, such as the feedback control of high-voltage dc (HVDC) links or static var compensators (SVCs), by using the PMU measurements. Additional benefits of using SMT, such as angle and voltage stability monitoring, line thermal monitoring, and online parameter estimation are included in the near-term goal.

### **China**

A well-developed measurement system comprised of several WAMSs is already in place in China. The Chinese standard on PMUs and WAMS was issued by the State Grid Company and manufacturers in 2005. More than 700 PMUs are already in operation. According to the 11th five-year plan of the power grid, all 500-kV substations and 300-MW and above power plants in the Chinese power grid will install PMUs within the next five years. Major applications that are currently in use are the real-time visualization of the system dynamics and transmission capacity, wide area data recording and playback, and monitoring of interarea low frequency oscillations. Work is in progress to include further applications such as enhanced state estimation, online security assessment, adaptive protection, and emergency control.

### **India**

In India, the central transmission utility, Powergrid, is planning to install 20–25 PMUs at critical buses in different regional grids. The synchronized measurements from these PMUs will be used for model validations and the develop-

ment of a common state estimator combining the regional state estimators. Based on the success of this stage, more PMUs will be installed to explore different advantages of SMT and develop remedial action schemes (RASS) and system integrity protection schemes (SIPSS).

### **Brazil**

The Brazilian independent system operator started two WAMS-related projects in 2000, aiming at the recording of wide-area disturbances and applying synchronized measurements for improved monitoring and control of the system. The preliminary study regarding the compliance and feasibility of integrating SMT-based devices into the existing measurement system, and the design of the integrated system architecture have been completed. A number of pilot projects for testing and validating SMT applications are in progress.

### **Russia**

More than 25 PMUs are in operation in the synchronously interconnected power system of 14 countries including Eastern Europe, Russia, Central Asia, and Siberia. The major application areas currently being served are the system performance monitoring, model validation, and monitoring of interarea oscillations. A procedure for dynamic model validation is developed, based on the measurements associated with a disturbance. Pilot projects are in operation for developing real-time control methodologies using synchronized measurements.

## **SMT Applications**

The continuing research on SMT reveals innovative applications in an increasing number of power system areas. The following list gives an overview of some of the important areas where significant improvement can be achieved by utilizing synchronized measurement technology:

- ✓ real-time visualization of power systems
- ✓ design of an advanced warning system
- ✓ analysis of the causes of a total or partial blackout
- ✓ benchmarking, validation, and fine-tuning of system models
- ✓ enhancement in state estimation
- ✓ real-time congestion management
- ✓ real-time angular and voltage stability analysis and enhancement
- ✓ improved damping of interarea oscillations
- ✓ design of an adaptive protection system.

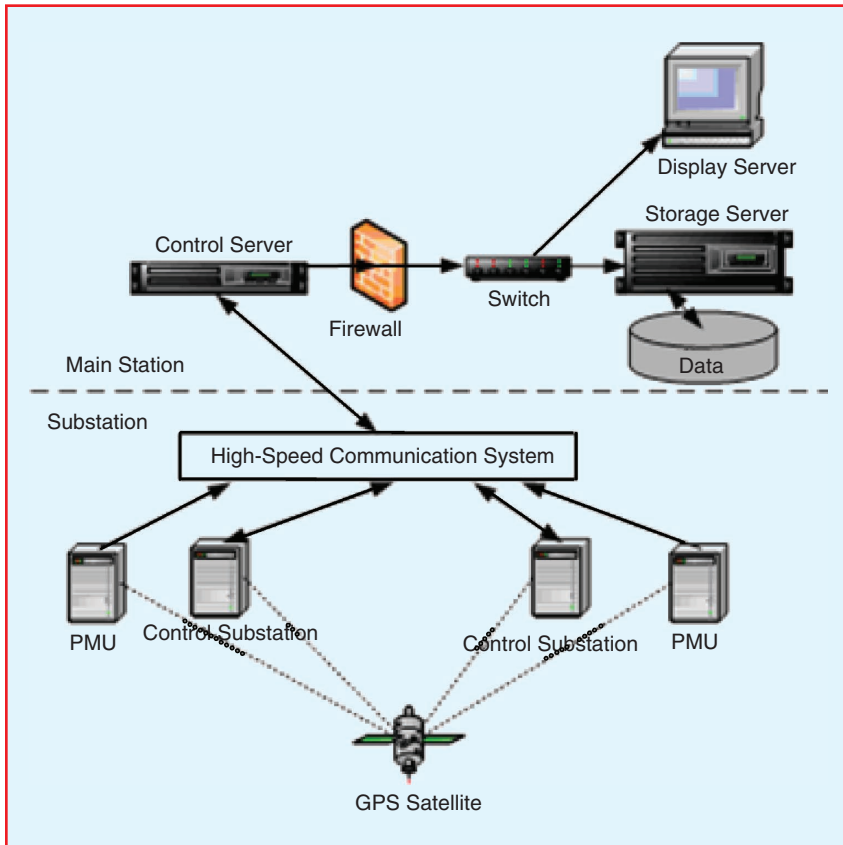

**figure 2.** Schematic diagram of WAMS-based wide area backup protection scheme.

We will describe the recent developments in some of these important applications.

### **WAMS Implementation for Wide Area Backup Protection**

Relay protection has always played an important role in safeguarding the secure operation of modern power systems. The performance of relay protection is evaluated by indices such as selectivity, sensitivity, reliability and interoperability. However, with the ongoing trend towards deregulation and interconnection of power systems, the traditional relay protection cannot keep pace with the demands of bulk power systems.

According to statistic data, relays are involved in one way or another in 75% of major disturbances (for more information the reader is referred to Phadke and Thorp in “For Further Reading”). One of the most important reasons is that the existing protections only utilize the local data and try to eliminate the faulted element or mal-operating condition as soon as possible without considering the impact of such an action on the whole system. If a network is already stressed, the unexpected occurrence of flow transferring might drive the system into cascading trips as some backup protection might lose their selectivity. Furthermore, the step principle for time setting of relay zones achieves selectivity at the sac-

rific of rapidity; the inborn time delay characteristic in clearing faulted lines might also undermine the stability and security of the power system. The investigations of blackouts in power systems around the world indicate that although the protective relays operated according to the pre-defined logic, the system status was deteriorated and finally collapsed.

The advent of WAMSs provides a platform for synchronous data acquisition, exchange and analysis, as the snapshot of the whole system can be updated every 20–50 ms. These features open a new path for enhancing the performance of power system protection, especially backup protection, since the time delay of backup protection makes it possible to acquire and deal with the synchronous data of power systems. It should be pointed out that, at the current stage of understanding in the field of SMT, the philosophy of the main protection should not be changed with the advent of WAMS. On one hand, acquisition of phasor measurements will inevitably increase the time delay of the trip signal, having an adverse impact to system stability. On the other hand, the introduction of WAMS information makes the main protection more complex, which might affect the reliability negatively. It can be concluded that WAMS-based backup protection integrated with local data-based main protection may be a promising methodology to protect bulk power systems against blackouts. Research work is being undertaken in this area.

On the other hand, the introduction of WAMS information makes the main protection more complex, which might affect the reliability negatively. It can be concluded that WAMS-based backup protection integrated with local data-based main protection may be a promising methodology to protect bulk power systems against blackouts. Research work is being undertaken in this area.

### **WAMS-Based Flow Transferring Identification Algorithm**

To handle the cascading trip problem caused by the unexpected occurrence of flow transferring in the power grids, the fundamental solution is to monitor the load and try to identify whether the overload is caused by flow transferring or an internal fault. If flow transferring does occur in the system, then the backup relay should be blocked before the thermal limits are exceeded, and enough time should be allowed for the system to take remedial measures to eliminate the overload.

By introducing wide area information into backup protection design, a novel wide area backup protection and control scheme to prevent cascading trips can be designed, based on Kirchhoff’s circuit law and linear circuit theory. By comparing the online measured post-fault flow with the estimated post-fault flow distribution, through this scheme, it can be readily determined whether the overload of the branches

The benefits of SMT compared to the conventional measurement technology are too obvious to ignore.

was caused by flow transferring, by comparing the online measured post-fault flow with the estimated post-fault flow distribution.

A new concept of flow transferring relativity factor (FTRF) is defined as a linear proportion coefficient in the transferring equivalent network to estimate the flow distribution after flow transferring occurs. Because FTRF is only determined by the topology and parameters of the network, FTRF can be calculated before the fault. Once the network topology is changed, which can be identified online by the breaker open/close status, the current FTRF matrix can be recalculated rapidly by amending the previous FTRF matrix.

To mitigate the overload caused by flow transferring, an equal-quantum generator tripping and load shedding control strategy can be also achieved based on the concept of the network correlation coefficient. The whole scheme integrates the online measurements of WAMS and can guaran-

tee simultaneously minimum control cost and eradication of cascading trips.

### Architecture of a WAMS-Based Wide Area Backup Protection Scheme

A practical WAMS-based wide area backup protection system has been developed based on a real power system, utilizing the wide area time synchronization capability and fast transmission speed of WAMS. This system adopts a centralized architecture and consists of four substations (including a PMU measurement substation and a control substation), a communications network (2M fiber green) and one main station. The schematic diagram of the WAMS-based wide area backup protection system is shown in Figure 2.

The main station and the substations are connected through the distributed network. The main station performs

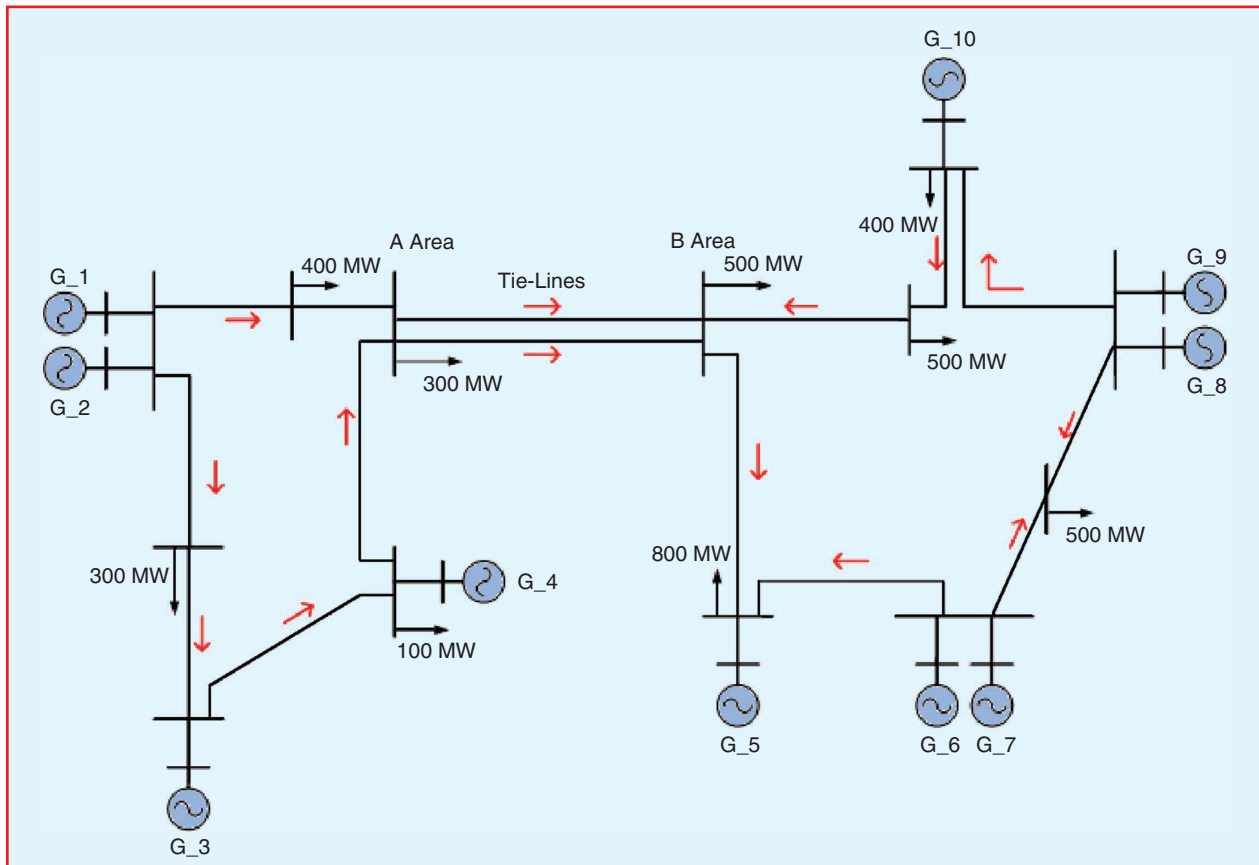
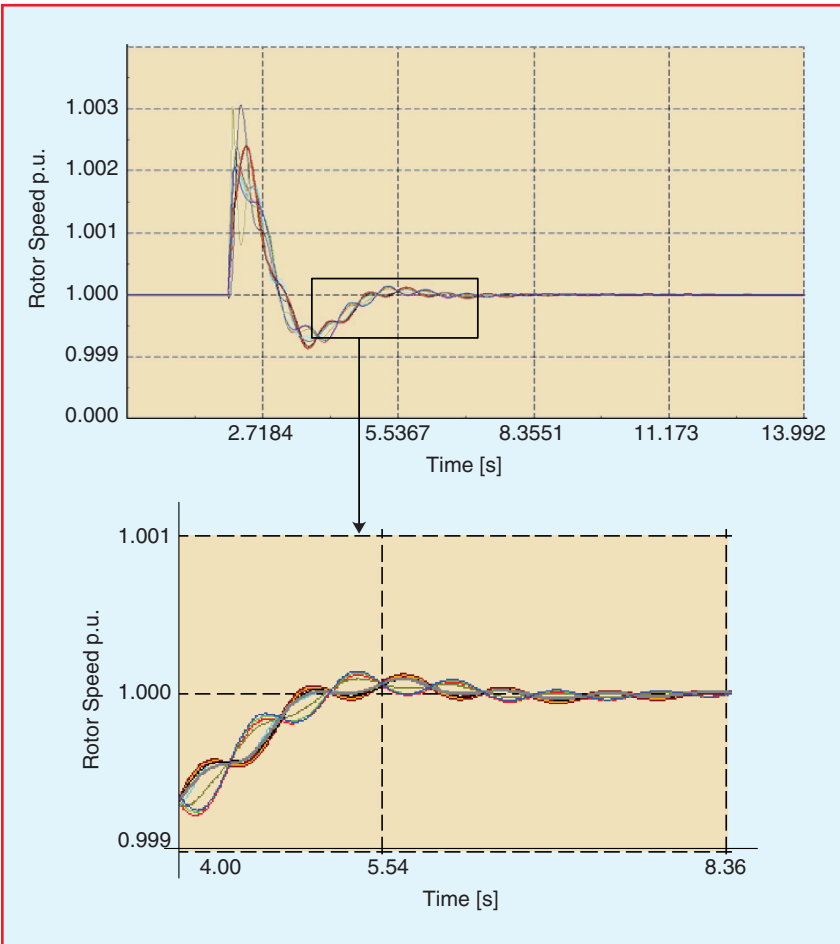

figure 3. Multimachine test power system.

**table 2. Dominant interarea oscillation modes of the test power system of Figure 3.**

Eigenvalue	Real Part	Imaginary Part	Period (s)	Frequency (Hz)	Damping
$\lambda_{72}$	-0.23923	6.244125	1.00625	0.99378	0.23923
$\lambda_{73}$	-0.23923	-6.244125	1.00625	0.99378	0.23923



**figure 4.** Instantaneous rotor speeds of all generators.

two main functions: the first is to collect, monitor, manage, and maintain the real-time synchronized phasor data and real-time switching information uploaded from the PMU measurement substations; the second is to diagnose wide area faults, judge protection logic, and issue control orders (such as tripping or blocking) to the control substations. The substation completes two major tasks: one is to sample, convert, and upload the real-time data; the other is to execute control orders received from the main station. The PMU measurement substation synchronizes the real-time phasor data and real-time switching information with a synchronized timestamp and forwards synchronized data to the main station. The function of the control substation is to realize the protection logic through an Ethernet network. The function of the storage server is to store and forward the historical data, and the function of the display server is to inquire historical

data and monitor the real-time power system operating status.

Synchronized phasor measurement technology is becoming mature; WAMS has been widely established in modern power grids and is becoming one of the most important data sources of dispatching centers. The large disturbances that occurred in recent years demonstrate the powerfulness of WAMS in the areas of dynamic monitoring and system modeling as well as parameter validation. However, the issue of how to integrate phasor data to develop advanced applications to reduce the probability of occurrence of blackouts is still an open one.

### **Monitoring of Power System Oscillations**

Real-time monitoring and identification of the characteristics of interarea oscillations, including damping factors and frequency of oscillations, is a prerequisite for applying corrective measures for system stabilization in large power systems. A wide area measurement approach based on the use of synchronized measurement technology leads to more efficient damping of interarea oscillations as well

as the prediction of instabilities which might cause cascading outages and, potentially, large-scale blackouts.

The eigenvalue analysis is a traditional method for offline analysis of dynamic properties of power systems. It is based on the assumed system model and the classical methods of linear systems control theory. With the help of eigenvalues, eigenvectors, and participation factors, the system characteristics can be predicted. However, this hardly meets the severe requirements for efficient monitoring of dynamically changed power systems possessing a high level of uncertainty. The system topology and state are dynamically changed. The system parameters are not constant. Renewable energy resources are introducing additional challenges due to their variable nature. All the above issues affect the suitability of the traditional eigenvalue analysis approach for determining the dynamic properties of modern power systems.

In the last two decades, a number of solutions for online monitoring and identification of power system oscillation modes were presented in the scientific literature. After detecting interarea oscillations (e.g., by using methods based on wavelet transform), damping and frequency components are commonly determined by applying methods based on the fast Fourier transform based techniques, or approaches based on different parameter estimation methods. The Prony method is one of the frequently used parameter estimators, capable of determining the unknown damping and frequency of the system oscillations. Using this method, oscillations can be analyzed

by processing various signals available through wide area measurements: local system frequency, speed of generators, and instantaneous active power through an intertie transmission line.

According to the dynamic properties of power systems and the range of low frequency oscillations, the oscillation modes are classified as local and interarea modes. The local modes may be associated with the internal speed oscillations of a single generator against the rest of the power system, which is similar to the behavior of a single-machine infinite bus system. In a multimachine power system, the oscillations between two groups of generators are described through the interarea oscillation modes. The 22-bus test power system with ten generators shown in Figure 3 is used to demonstrate the interarea oscillation modes. From the topology of the test power system, two areas, A and B, connected over two parallel intertie lines can be noted. Under steady-state conditions, a 500-MW active power is transferred over the intertie line from area A to the area B.

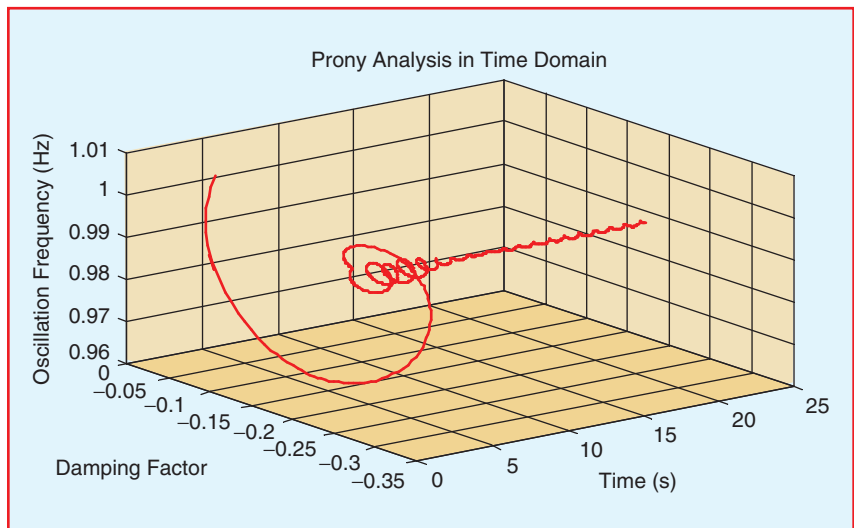

**figure 5.** Prony analysis of the oscillating power over the intertie line.

The classical eigenvalue analysis method is compared with the results obtained by using the Prony method. Based on the eigenvalue analysis, the dominant interarea oscillation modes  $\lambda_{72}$  and  $\lambda_{73}$  are shown in Table 2 (note that there are 131 oscillation modes in the multimachine system of Figure 3).

To apply the Prony method for determining the unknown damping and oscillation of the dominant interarea oscillations, a single line-to-ground fault at one of the two parallel intertie lines, starting at  $t = 2$  s and lasting for 100 ms is simulated. The fault provoked severe oscillations at all interconnected generators (see Figure 4, in which the instantaneous rotor speeds of all generators are presented). The oscillations between two coherent groups of generators (groups A and B) are obvious.

For this temporary short circuit, the active power flow (see Figure 5) over the sound intertie line from Figure 3 was used as an input to the Prony method. In Table 3, the unknown frequency and damping of the dominant oscillation

**table 3. Comparison of results obtained from eigenvalue analysis and Prony method.**

Results	Dominant Oscillation Damping	Dominant Oscillation Frequency (Hz)
Eigenvalue analysis	0.23923	0.99378
Approximate results by Prony method (mean value from sliding windows)	0.23816	0.99417
Relative errors (%)	<b>0.447</b>	<b>0.04</b>

**table 4. PMU placement methodologies.**

Technique	Advantages	Disadvantages
Integer programming Evolutionary techniques, such as genetic algorithm, simulated annealing, particle swarm optimization	Less computational time, applicable for systems of any size Elimination of the problem of local minima, virtually any type of constraints can be incorporated	Existence of local minima, not all constraints can be expressed in simple mathematical form Large computational time, free parameters of the algorithms need to be tuned carefully to get the optimal solution

## Synchronized measurement technology has the potential of becoming the backbone of a real-time wide area monitoring, protection, and control system.

mode, estimated from the processed active power, are presented. For comparison reasons, in the same table, the results obtained from eigenvalue analysis are also presented. It is obvious that the Prony method delivered practically useful results, which provides the operator with the information that the oscillations are damped. Furthermore, the estimated damping and frequency of the dominant mode can be forwarded to the power system stabilizer (PSS) to control the damping of the oscillations. The use of wide area information of damping could lead to more efficient stabilization of slow oscillations in the system.

The results obtained by using the Prony method correspond to the results obtained over the classical eigenvalue analysis. Based on the results, it is possible to design an efficient early instability predictor. The functionality of such a predictor would be based on the analysis of the value of the damping estimated over the Prony method. For a negative damping, an alarm signal should be issued and the operator should be warned to initialize a corrective action to prevent the instability.

### Challenges

SMT is a relatively new technology and has received significant attention from power system researchers in recent years. At present, the industry practice is to install PMUs in an incremental fashion in conjunction with conventional measurements such as power flow and power injection. As the cost of PMUs is reducing, they will be used in greater numbers, probably to achieve full system observability based on PMUs or improvement in the state estimator performance. However, conventional measurements will continue to be used in parallel to the PMUs, enhancing the robustness of state estimation and ensuring system observability in the case of device or component outages. The techniques to find the optimal location of PMUs in a power system both in the presence and in the absence of conventional measurements should therefore be available to the system planners. The existing approaches to the problem of optimal PMU placement are summarized in Table 4. The issues such as measurement redundancy and uncertainty should also be considered while placing the PMUs. In the presence of conventional measurements, one important criterion for PMU placement is the improvement of existing state estimator performance. For example, a frequently encountered problem in state estimation is the large value of the condition number of the gain matrix. (The condition number is a measure of how ill-conditioned a gain matrix is, i.e., a measure of sensitivity to numerical operations. A large con-

dition number indicates that we may not be able to trust the results of computations for that gain matrix.) The PMU placement can be done in such a way that the condition number of the gain matrix is reduced when PMU measurements are combined with conventional measurements.

As the number of installed SMT-based devices in a power system increases, the communication network will be increasingly congested. Two approaches exist to cope with this challenge: increasing the communication bandwidth and reducing the volume of transmitted data by using data compression techniques and/or transmission of only the important data. One or both of these approaches along with proper data management protocols will help in alleviating the congestion of communication channels, increasing the security of the data against possible disturbances or malicious attacks, and reducing the latency in the transmitted information (thereby helping in the realization of the wide area control system). Several options exist for high-speed wide area communications, including frame relay, switched multimegabit data service (SMDS), digital subscriber line (DSL), asynchronous transfer mode (ATM), and synchronous optical network (SONET).

Another challenging area is the integration of synchronized measurements with the conventional measurements. A state estimation method such as the least-squares error (LSE) estimator should be used to estimate the states of the power system based on the measurements obtained from the PMUs. In the presence of conventional measurements, such as the asynchronous remote terminal unit (RTU)-SCADA measurements, the nonlinear LSE estimator is in use. This is the consequence of the fact that the network model is nonlinear. The nonlinearities are caused by the unknown phase angles, which are considered as unknown model parameters to be estimated. It is known that nonlinear estimators require essentially more computational time compared to linear ones. In addition, the convergence properties of nonlinear estimators are not as sophisticated as in the case of linear estimators. In the case that only synchronized measurements are used, the estimator will be linear; however, such a case is still far away. In fact, the nonlinearity of the state estimator is a sweet price to be paid for the enhanced robustness provided by the larger redundancy of combined SCADA/PMU measurements. The PMU measurements can be synchronized with the conventional measurements by using the time stamps. To determine the best time at which the PMU data is to be used with other measurements requires

extensive system-specific case studies. An interesting area of investigation is the use of high-fidelity synchronized data to detect, identify, and process bad data in the conventional measurements.

PMUs offer highly accurate measurements of voltage and current phasors and frequency when operating under steady-state conditions and nominal frequency. Significant error creeps into the measurements, however, while operating under transient conditions or off-nominal frequencies. The amount of measurement error varies from one manufacturer to another due to the difference in the algorithm used to compute the output quantities. This poses a serious question to the SMT's ability to monitor dynamics of a power system at the time of disturbances. The current version of IEEE Standard C37.118 for synchrophasors specifies the acceptable limit on the total vector error (TVE) of synchronized measurements under such conditions. More detailed compliance criteria need to be developed to harvest maximum benefit of the SMT for monitoring, protection and control of a power system under all operating conditions.

## Roadmap for SMT Penetration into the Power Industry

The power industries need to develop a clearly defined roadmap for adopting SMT. This roadmap should include both short-term objectives such as enhanced visualization of the power system, post-disturbance analysis, and model validations, and long-term objectives such as the development of a wide area monitoring, protection and control system. In a major part of the world, PMU deployment is in the initial stage, involving the evaluation of pilot projects experimenting with the operational capabilities of PMUs. A number of areas that need to be addressed while planning and designing for wide-scale deployment of PMUs are the following:

- ✓ *Compatibility*: A thorough investigation needs to be carried out to examine the compatibility of SMT-based devices with the existing measurement system. The availability of the required bandwidth and communication facilities is a prerequisite for PMU deployment. To simplify this problem, some manufacturers are coming up with software-only upgrade facilities, i.e., PMU capability can be added to the existing relays and meters with a software upgrade, without requiring any hardware changes.
- ✓ *Optimal placement*: The usual practice is to install PMUs in an incremental fashion in conjunction with the existing measurement devices. A number of criteria should be kept in mind while determining the optimal PMU locations such as the observability of the system, the strategic importance of the load or generator buses, and the possibility of future expansion.
- ✓ *Flexibility*: The design of the system architecture involving PMUs should be flexible enough to accommodate new measurement devices and additional measurement load from any future expansion in the system.

- ✓ *Protocols*: Standard network protocols need to be developed for handling the synchronized devices and associated measurements, and storage and usage of the measured data. This will help in seamless integration of new devices from different manufacturers into the existing system and easy handling of the measurement data from different locations.

SMT is a relatively new technology and still in the development stage. This article presented a brief account of the existing practices in some of the major world economies, the major challenges to the integration of SMT into the existing power systems, and highlighted some of the major innovative application areas. However, the benefits of SMT compared to the conventional measurement technology are too obvious to ignore. Significant research activities are taking place in different parts of the world for the development of methodologies and techniques for the large-scale deployment of PMUs in power systems.

## For Further Reading

A.G. Phadke, et al., "The wide world of wide-area measurement," *IEEE Power Energy Mag.*, vol. 6, no. 5, pp. 52–65, Sep./Oct. 2008.

North American SynchroPhasor Initiative (NASPI), [Online]. Available: <http://www.naspi.org/>

D. Novosel, V. Madani, B. Bhargava, K. Vu, and J. Cole, "Dawn of the grid synchronization," *IEEE Power Energy Mag.*, vol. 6, no. 1, pp. 49–60, Jan./Feb. 2008.

A.G. Phadke and J.S. Thorp, "Expose hidden failures to prevent cascading outages," *IEEE Comput. Applicat. Power*, vol. 9, no. 3, pp. 20–23, 1996.

J.C. Tan, P.A. Crossley, P.G. McLaren, P.F. Gale, I. Hall, and J. Farrell, "Application of a wide area backup protection expert system to prevent cascading outages," *IEEE Trans. Power Delivery*, vol. 17, no. 2, pp. 375–380, 2002.

D.J. Trudnowski, J.M. Johnson, and J.F. Hauer, "Making Prony analysis more accurate using multiple signals," *IEEE Trans. Power Syst.*, vol. 14, no. 1, pp. 226–231, Feb. 1999.

V. Terzija, "Adaptive underfrequency load shedding based on the magnitude of the disturbance estimation," *IEEE Trans. Power Syst.*, vol. 21, no. 3, pp. 1260–1266, Aug. 2006.

## Biographies

**Saikat Chakrabarti** is a research associate at the Queensland University of Technology in Australia.

**Elias Kyriakides** is a lecturer at the Department of Electrical and Computer Engineering at the University of Cyprus.

**Tianshu Bi** is a professor of Electrical and Electronic Engineering at North China Electric Power Institute.

**Deyu Cai** is a Ph.D. student at the University of Manchester.

**Vladimir Terzija** is the EPSRC Chair Professor in Power System Engineering at the School of Electrical and Electronic Engineering at the University of Manchester. 