

QUT Digital Repository:  
<http://eprints.qut.edu.au/>



Chakrabarti, Saikat and Venayagamoorthy, Ganesh and Kyriakides, Elias (2008) *PMU placement for power system observability using binary particle swarm optimization*. In: Australasian Universities Power Engineering Conference, 14-17 December 2008, Sydney.

© Copyright 2008 IEEE

# PMU Placement for Power System Observability using Binary Particle Swarm Optimization

S. Chakrabarti, *Member, IEEE*, G. K. Venayagamoorthy, *Senior Member, IEEE*, and E. Kyriakides, *Member, IEEE*

**Abstract**—A binary particle swarm optimization (BPSO) based methodology for the optimal placement of phasor measurement units (PMUs) for complete observability of a power system is presented in this paper. The objectives of the optimization problem are to minimize the total number of PMUs required, and to maximize the measurement redundancy at the power system buses. Simulation results on the IEEE 14-bus and 30-bus test systems are presented in this paper.

**Index Terms**—Binary particle swarm optimization, observability, optimal placement, phasor measurement units.

## I. INTRODUCTION

Synchronized measurement technology (SMT) facilitates the realization of the real-time wide area monitoring, protection, and control (WAMPAC) of a power system. The major advantages of using SMT are that (1) the measurements from widely dispersed locations can be synchronized with respect to a global positioning system (GPS) clock, (2) voltage phase angles can be measured directly, which was so far technically infeasible, and (3) the accuracy and speed of state estimation increases manifold. Phasor measurement units (PMUs) are the most accurate and advanced instruments utilizing SMT available to the power system engineers and system operators [1]. The PMUs, when placed at a bus, can offer time-synchronized measurements of the voltage and current phasors at that bus [2].

A suitable methodology is needed to determine the optimal locations of the synchronized measurement devices, so that the number of PMUs required to make the system completely observable is minimized. A power system is considered completely observable when all the states in the system can be uniquely determined [3], [4].

In recent years, there has been a significant research activity on the problem of finding the minimum number of PMUs for making a power system completely observable, and their optimal locations. In [5], a bisecting search method is imple-

mented to find the minimum number of PMUs to make the system observable. The simulated annealing method is used to randomly choose the placement sets to test for observability at each step of the bisecting search. In [6], the authors use a simulated annealing technique in their graph-theoretic procedure to find the optimal PMU locations. In [7], a genetic algorithm is used to find the optimal PMU locations. The minimum number of PMUs needed to make the system observable is found by using a bus-ranking methodology. The authors in [8] use the condition number of the normalized measurement matrix as a criterion for selecting the candidate solutions, along with binary integer programming to select the PMU locations.

In [9] and [10], the authors use integer programming to find the minimum number and locations of PMUs. However, the issue of measurement redundancy was not addressed, and the problem of local minima may affect the solution. In [11] and [12] the authors propose an exhaustive search based methodology to determine the minimum number and optimal locations of PMUs for complete observability of the power system. Although the method gives the global optimal solution to the PMU placement problem, it becomes computationally intensive for large systems.

The particle swarm optimization (PSO) technique has been used successfully in a number of power system applications [13]. In this work, a binary particle swarm optimization (BPSO) based method is used to achieve dual objectives: (a) to minimize the required number of PMUs and (b) to maximize the measurement redundancy.

Section II of this paper explains the basic rules of the PMU placement methodology. A brief discussion of the BPSO and its enhanced version is presented in Section III to make the paper self-contained. The important steps of the proposed optimal PMU placement methodology using BPSO is described in Section IV. Case studies and analysis of the results are given in Section V, and Section VI concludes the paper.

## II. PLACEMENT OF PMUS FOR OBSERVABILITY

The basic rule of PMU placement is that, when a PMU is placed at a bus, it can measure the voltage phasor at that bus, as well as at the buses at the other end of all the incident lines, using the measured current phasor and the known line parameters [11], [12]. It is assumed in this study that the PMU has a sufficient number of channels to measure the current phasors

This work was partly supported by the Cyprus Research Promotion Foundation under grant ΠΔΕ/0505/06. The authors are with the Queensland University of Technology, Brisbane, Australia (saikat.chakrabarti@gmail.com), University of Cyprus, Nicosia, Cyprus (elias@ucy.ac.cy), and Missouri University of Science and Technology (gkumar@ieee.org).

through all branches incident to the bus at which it is placed. Fig. 1 illustrates the observable region of a PMU.

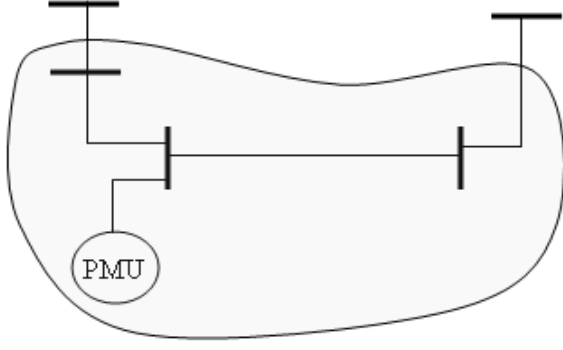

Fig. 1. Observable region of a PMU

When there is no power injection at a bus, the power flow in any one of the connected lines can theoretically be determined by using Kirchhoff's current law (KCL), when the power flow in the remaining of the connected lines are known. This approach is used by some researchers while finding optimal PMU locations [9], [10]. However, the voltage phasors measured or estimated by the PMU are subjected to the errors in the measurement of voltage or current magnitudes and phase angles and the uncertainties in the transmission line parameters [14], [15]. The measurement uncertainties propagate further due to the use of KCL. In this paper, the use of current measurements by the PMUs to estimate voltage phasors is therefore limited only to the adjacent buses.

The PMU placement methodology presented in this paper serves two objectives: (1) it minimizes the number of PMUs needed to make the system completely observable, and (2) it maximizes the measurement redundancy at the buses. The binary particle swarm optimization (BPSO) method is used to achieve these two objectives. The following section gives an overview of the BPSO used in this work.

### III. BINARY PARTICLE SWARM OPTIMIZATION

The basic principles of PSO are taken from the collective movement of a flock of bird, a school of fish, or a swarm of bees [13], [16]. A number of agents or particles are employed in finding the optimal solution for the problem under consideration. The movement of the particles towards finding the optimal solution is guided by both individual and social knowledge of the particles. As shown below, the position of a particle at any instant is determined by its velocity at that instant and the position at the previous instant.

$$\mathbf{x}_i(t) = \mathbf{x}_i(t-1) + \mathbf{v}_i(t), \quad (1)$$

where  $\mathbf{x}_i(t)$  and  $\mathbf{x}_i(t-1)$  are the position vectors of the  $i$ th particle at the instant  $t$  and  $t-1$  respectively, and  $\mathbf{v}_i(t)$  is the velocity vector of the particle.

The velocity vector is updated by using the experience of the individual particles, as well as the knowledge of the performance of the other particles in its neighbourhood. The velocity update rule for a basic PSO is,

$$\mathbf{v}_i(t) = \mathbf{v}_i(t-1) + \varphi_1 \cdot r_1 \cdot (\mathbf{pbest}_i - \mathbf{x}_i(t-1)) + \varphi_2 \cdot r_2 \cdot (\mathbf{gbest} - \mathbf{x}_i(t-1)), \quad (2)$$

where  $\varphi_1$  and  $\varphi_2$  are adjustable parameters called individual and social acceleration constant respectively;  $r_1$  and  $r_2$  are random numbers in the range  $[0, 1]$ ;  $\mathbf{pbest}_i$  is the best position vector found by the  $i$ th particle;  $\mathbf{gbest}$  is the best among the position vectors found by all the particles.

The vectors  $\mathbf{pbest}_i$  and  $\mathbf{gbest}$  are evaluated by using a suitably defined fitness function.  $\varphi_1$  and  $\varphi_2$  are usually defined such that  $\varphi_1 + \varphi_2 = 4$ , with  $\varphi_1 = \varphi_2 = 2$ . The maximum and minimum values of the components of velocity are limited by the following constraints to avoid large oscillations around the solution.

$$v_{ij} = \begin{cases} -v_{\max} & \text{if } v_{ij} < -v_{\max} \\ v_{\max} & \text{if } v_{ij} > v_{\max} \end{cases}, \quad (3)$$

For the problem under investigation in this paper,  $v_{\max}$  is taken to be equal to 4 [13].

#### A. Binary PSO

In a BPSO, each element of the position vector can take only binary values, i.e., 1 or 0. At each stage of iteration, the elements of the position vector  $\mathbf{x}_i$  are updated according to the following rule:

$$x_{ij}(t) = \begin{cases} 1 & \text{if } \rho_{ij} < s(v_{ij}) \\ 0 & \text{otherwise} \end{cases}, \quad (4)$$

where  $\rho_{ij}$  is a random number in the range  $[0, 1]$ ,  $s(v_{ij})$  is a sigmoidal function defined as,

$$s(v_{ij}) = \frac{1}{1 + \exp(-v_{ij})}, \quad (5)$$

#### B. Enhanced PSO

The enhancement to the basic PSO proposed in [17] is used in this work for increasing the efficiency of the search process. The rules, additional to the one described in (2) for updating the velocity vector, are as follows:

1. If the individual best solution found by the particle,  $\mathbf{pbest}_i$ , and the best solution found by all the particles,  $\mathbf{gbest}$  are both feasible solutions in terms of satisfying all the constraints for the problem, then the velocity of the particle is updated according to (2).
2. If the particle has not found a solution, i.e.,  $\mathbf{pbest}_i$  is not feasible, but the global best solution  $\mathbf{gbest}$  is feasible, its velocity is updated by the following rule:

$$\mathbf{v}_i(t) = \mathbf{v}_i(t-1) + \varphi \cdot r \cdot (\mathbf{gbest} - \mathbf{x}_i(t-1)), \quad (6)$$

where  $\varphi = \varphi_1 + \varphi_2$ ,  $r$  is a random number in the range  $[0, 1]$ .

3. If none of the particles has found a solution so far, i.e., both  $\mathbf{pbest}_i$  and  $\mathbf{gbest}$  are infeasible, the components of the velocity of the particle are set to random fractions of the maximum values of the corresponding components as shown below.

$$\mathbf{v}_i(t) = [m_1 \cdot v_{1\max}, m_2 \cdot v_{2\max}, \dots, m_D \cdot v_{D\max}], \quad (7)$$

where  $m_j, \forall j=1, \dots, D$  are random numbers in the range  $[-1, 1]$ ;  $v_{j\max}, \forall j=1, \dots, D$  are the maximum specified values of the velocity components;  $D$  is the dimension of the velocity vector.

The main principle behind the enhanced PSO is that, when an individual particle is not able to find a feasible solution, it should use the knowledge of the feasible solution, if any, found by some other particle. When none of the particles has found a feasible solution, a random search enhances the possibility of quickly finding a feasible solution.

#### IV. PMU PLACEMENT BY BPSO

The first step in placing the PMUs is the identification of candidate locations. In a power system, there may be certain buses that are strategically important, so that a PMU must be placed at each of those buses. The rest of the buses are made observable by placing a minimum number of additional PMUs. The radial buses are excluded from the list of potential locations for placing a PMU because a PMU placed at a radial bus can measure the voltage phasors at that bus and only one additional bus that is connected to it, and a PMU placed at the bus connected to the radial bus can measure the voltage phasor of the radial bus by using the measurement of the current phasor through the radial line. Therefore, a PMU is pre-assigned to each bus connected to a radial bus. Pre-assigning PMUs to certain buses in this manner reduces the total number of possible combinations of PMU locations, thereby reducing the computational burden.

The position vectors of the particles represent the potential solutions for the PMU placement problem. As mentioned in Section III, a fitness function needs to be defined to evaluate the suitability of the solutions found by the particles at each stage of iteration. The individual best position vector of a particle,  $\mathbf{pbest}_i$ , and the global best position vector  $\mathbf{gbest}$  are evaluated based on this fitness function. The objective of the PMU placement problem in this paper is to minimize the number of PMUs that can make the system observable, and to maximize the measurement redundancy in the system. The fitness function therefore should evaluate, for the position vector of each particle, (1) whether the system is observable, (2) in case it is observable, what is the number of PMUs employed, and (3) the measurement redundancy. The measurement redundancy is defined as in [18]: the redundancy level of a measurement is equal to the number  $(p-1)$  which corresponds to the smallest critical  $p$ -set to which the measurement belongs. For instance, if the number of times a bus is observed by a PMU is increased by one, the measurement redundancy at that bus is also increased by one. The fitness function  $J(\mathbf{x})$  for using BPSO is formulated as follows:

$$J(\mathbf{x}) = \begin{cases} K & , \text{if the system is unobservable} \\ w_1 J_1 + w_2 J_2 & , \text{if the system is observable} \end{cases}, \quad (8)$$

where  $K$  is a large number assigned to the fitness function if the position vector representing the PMU placement solution is

not able to make the system observable;  $w_1$  and  $w_2$  are two weights with values such that  $w_1 J_1$  and  $w_2 J_2$  are comparable in magnitude.  $J_1$  and  $J_2$  are the parts of the fitness function representing the total number of PMUs and the measurement redundancy respectively, and are defined as follows:

$$J_1 = \mathbf{x}^T \mathbf{x}, \quad (9)$$

$$J_2 = (\mathbf{N} - \mathbf{A}\mathbf{x})^T (\mathbf{N} - \mathbf{A}\mathbf{x}) \quad (10)$$

The elements of the binary vector  $\mathbf{x}$  are defined as follows:

$$x_i = \begin{cases} 1 & \text{if a PMU is placed at bus } i \\ 0 & \text{otherwise} \end{cases}, \quad (11)$$

The elements of the binary connectivity matrix  $\mathbf{A}$  for a power system are defined as,

$$\mathbf{A}(i, j) = \begin{cases} 1 & \text{if } i = j \\ 1 & \text{if bus } i \text{ and } j \text{ are connected.} \\ 0 & \text{otherwise} \end{cases}. \quad (12)$$

The entries of the product  $\mathbf{A}\mathbf{x}$  in (10) therefore represent the number of times a bus is observed by the PMU placement set defined by  $\mathbf{x}$ . Since the elements in  $\mathbf{x}$  are either 0 or 1,  $J_1$  represents the total number of PMUs in the system. The vector  $\mathbf{N}$  can be chosen according to the desired level of measurement redundancy in the system. For example, if a measurement redundancy level of 2 is desired at all buses, all the elements of  $\mathbf{N}$  are set to 3. The vector  $(\mathbf{N} - \mathbf{A}\mathbf{x})$  computes the difference between the desired and actual number of times a bus is observed. Minimization of this difference is therefore equivalent to maximizing the measurement redundancy. The term  $J_2$  is therefore a metric for the measurement redundancy offered by the PMU placement set.

The total number of possible combinations of PMU locations,  $N_{\text{solution}}$ , for a given number of candidate locations and number of PMUs is shown below:

$$N_{\text{solution}} = \frac{N_{\text{bus}}!}{N_{\text{PMU}}!(N_{\text{bus}} - N_{\text{PMU}})!}, \quad (13)$$

where  $N_{\text{PMU}}$  is the total number of PMUs deployed in the system, and is equal to the number of non-zero elements in the vector  $\mathbf{x}$ .

The total number of possible combinations of PMU locations becomes large as the size of the power system increases. BPSO is found to be an efficient search method in this work for finding the most suitable PMU placement solution among the large number of possible combinations.

#### V. CASE STUDIES

The proposed PMU placement method is applied to the IEEE 14-bus and 30-bus systems [19]. The single-line diagrams of the test systems are shown in Figs. 2 and 3.

The radial buses are eliminated from the potential PMU locations for reasons described in Section IV. Table I shows the number of radial buses in each of the test systems. The computational burden is further reduced by pre-assigning PMUs to a bus connected to a radial bus in order to make all radial buses observable.

TABLE I  
NUMBER OF RADIAL BUSES IN THE TEST SYSTEMS

Test systems	No. of radial buses
IEEE 14-bus	1
IEEE 30-bus	3

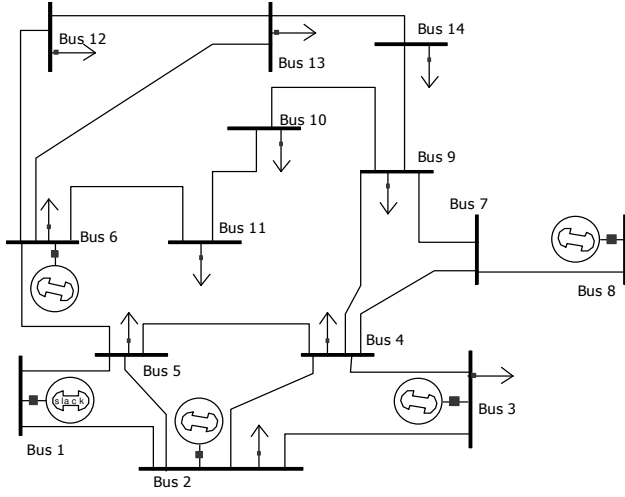

Fig. 2. IEEE 14-bus test system [19]

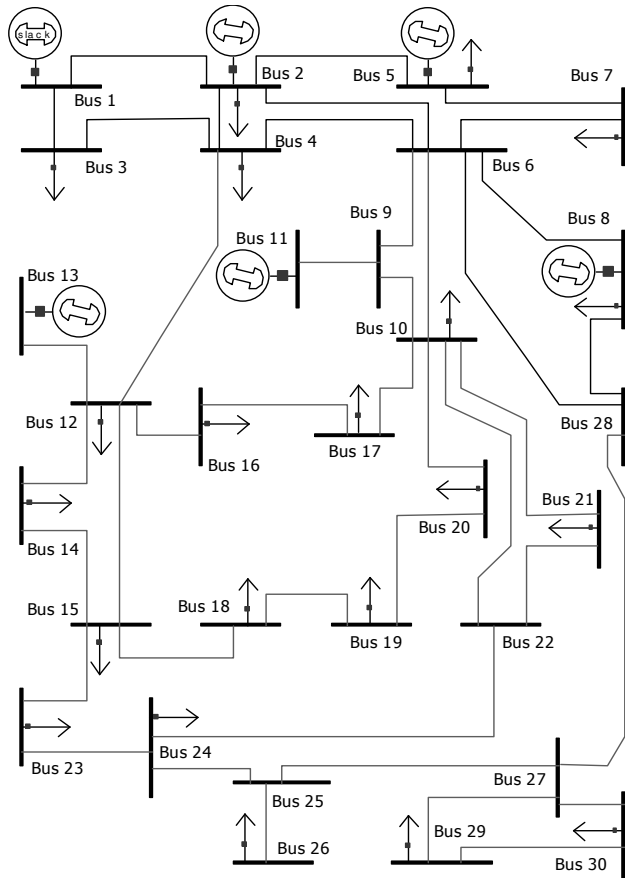

Fig. 3. IEEE 30-bus test system [19]

Table II shows the chosen values of the parameters for the BPSO used for the PMU placement problem. These values are chosen after multiple runs of the algorithm, and offer best per-

formance in terms of finding the optimal solution and computational time.

Table III shows the optimal PMU locations for the 14-bus system with and without the consideration of measurement redundancy. The first set of PMU locations in Table III is obtained by minimizing the number of PMUs only, while ensuring the complete observability of the system. The second set of PMU locations in Table III is obtained by minimizing the number of PMUs, as well as maximizing the measurement redundancy at the buses. The target value for the measurement redundancy is taken as 2, i.e., all the elements of the vector  $\mathbf{N}$  in (10) are set to 3. Table IV shows the improvement in the distribution of measurement redundancy at the buses in the case of the second solution described above. The second column in Table IV shows the number of times the buses 1 to 14 in the 14-bus system are observed by the two different PMU placement sets. The number of times the buses 4, 5 and 7 are observed is more in the second case, compared to the first case. Table V shows the optimal PMU locations for the 30-bus test system, obtained by using the proposed methodology.

TABLE II  
BPSO PARAMETERS

Parameter	Optimal value
Number of particles	$5 * N_{bus}$
Individual acceleration constant ( $\varphi_1$ )	2
Social acceleration constant ( $\varphi_2$ )	2
Number of iterations after which the search is stopped if no better solution is found	50
Maximum number of iterations	$100 * N_{bus}$

TABLE III  
OPTIMAL LOCATIONS OF PMUS FOR THE IEEE 14-BUS TEST SYSTEM

System configuration	Optimal PMU locations
Normal operating conditions, without maximizing measurement redundancy	2, 7, 10, 13
Normal operating conditions, maximizing measurement redundancy	2, 6, 7, 9

TABLE IV  
EFFECT OF THE MAXIMIZATION OF PMU MEASUREMENT REDUNDANCY ON THE 14-BUS TEST SYSTEM

PMU locations	Number of times each bus is observed
2, 7, 10, 13	1, 1, 1, 2, 1, 1, 1, 1, 1, 2, 1, 1, 1, 1, 1
2, 6, 7, 9	1, 1, 1, 3, 2, 1, 2, 1, 2, 1, 1, 1, 1, 1

TABLE V  
OPTIMAL LOCATIONS OF PMUS FOR THE IEEE 30-BUS TEST SYSTEM

System configuration	Optimal PMU locations
Normal operating conditions	1, 5, 6, 9, 10, 12, 15, 19, 25, 27

The minimum number of PMUs needed to make the system observable under normal operating conditions for the IEEE 14-bus and IEEE 30-bus systems are the same as found in [12] (which presents the global optimal solution found by exhaustive search). The optimal PMU locations for the 14-bus system using the method proposed in this paper are on buses 2, 7, 10, and 13, while in [12] the global optimal solution is given as 2, 6, 7, and 9 (which was the best among three candidate solutions in that paper, the choosing criterion being the maximum measurement redundancy). Interestingly, the latter is the solu-

tion found using the proposed method, when the second objective of maximizing the measurement redundancy is considered. In the case of the 30-bus system, the solution obtained through the BPSO is the same as in [12] except for bus 2 which is replaced by bus 5 in this paper.

## VI. CONCLUSIONS

A new methodology for the optimal placement of PMUs for making a power system topologically observable is proposed in this paper. A binary particle swarm optimization (BPSO) based approach is used to determine the optimal locations of PMUs. The optimization process tries to attain dual objectives: (a) to minimize the number of PMUs needed to maintain complete observability of the system, and (b) to maximize the measurement redundancy at all buses in the system. The method was successfully applied on IEEE test systems. The main contribution of this work lies in investigating the feasibility of using BPSO for the PMU placement problem. Future work will include additional constraints into the PMU placement problem, such as the existence of conventional measurements, user-defined measurement redundancy at the buses, and the consideration of measurement uncertainty. These constraints are difficult to handle by conventional optimization methods. The promising results presented in this paper will encourage the researchers in using BPSO for the larger problem described above.

## VII. REFERENCES

- [1] D. Novosel, V. Madani, B. Bhargava, K. Vu, and J. Cole, "Dawn of the grid synchronization," *IEEE Power and Energy Magazine*, vol. 6, no. 1, pp. 49-60, Jan/Feb. 2008.
- [2] Real time dynamics monitoring system. [Online]http://www.phasor-rtdms.com
- [3] A. Monticelli, *State Estimation in Electric Power Systems: A Generalized Approach*, Boston: Kluwer Academic Publishers, 1999.
- [4] A. Abur and A. G. Exposito, *Power System State Estimation: Theory and Implementation*, New York: Mercel Dekker, 2004.
- [5] T. L. Baldwin, L. Mili, M. B. Boisen, Jr., and R. Adapa, "Power system observability with minimal phasor measurement placement," *IEEE Trans. Power Systems*, vol. 8, no. 2, pp. 707-715, May 1993.
- [6] R. F. Nuqui and A. G. Phadke, "Phasor Measurement Unit placement techniques for complete and incomplete observability," *IEEE Trans. Power Delivery*, vol. 20, no. 4, pp. 2381-2388, Oct. 2005.
- [7] B. Milosevic and M. Begovic, "Nondominated sorting genetic algorithm for optimal phasor measurement placement," *IEEE Trans. Power Systems*, vol. 18, no. 1, pp. 69-75, Feb. 2003.
- [8] C. Rakpenthai, S. Premrudeepreechacharn, S. Uatrongjit, and N. R. Watson, "An optimal PMU placement method against measurement loss and branch outage," *IEEE Trans. Power Delivery*, vol. 22, no. 1, pp. 101-107, Jan. 2005.
- [9] B. Xu and A. Abur, "Optimal placement of phasor measurement units for state estimation," Final project report, PSERC, Oct. 2005.
- [10] B. Xu and A. Abur, "Observability analysis and measurement placement for systems with PMUs," *IEEE PES Power Systems Conference and Exposition*, pp. 943-946, Oct. 2004.
- [11] S. Chakrabarti and E. Kyriakides, "Optimal placement of phasor measurement units for state estimation," *7<sup>th</sup> IASTED International Conference on Power and Energy Systems, EuroPES 2007*, Spain, Aug. 2007.
- [12] S. Chakrabarti and E. Kyriakides, "Optimal placement of phasor measurement units for power system observability," *IEEE Trans. Power Systems*, vol. 23, no. 3, pp. 1433-1440, Aug. 2008.
- [13] Y. del Valle, G. K. Venayagamoorthy, S. Mohagheghi, J. C. Hernandez, and R. G. Harley, "Particle swarm optimization: basic concepts, variants and applications in power systems," *IEEE Trans. Evolutionary Computation*, vol. 12, no. 2, pp. 171-195, Apr. 2008.
- [14] S. Chakrabarti, D. Eliades, E. Kyriakides, and M. Albu, "Measurement Uncertainty Considerations in Optimal Sensor Deployment for State Estimation", *IEEE Symposium on Intelligent Signal Processing (WISP 2007)*, Madrid, Spain, Oct. 2007.
- [15] S. Chakrabarti, E. Kyriakides, and M. Albu, "Uncertainty in power system state variables obtained through synchronized measurements," *IEEE Trans. on Instrumentation and Measurement*, (accepted), July 2008.
- [16] J. Kennedy and R. C. Eberhart, "Particle Swarm Optimization," *Proceedings of the 1995 IEEE International Conference on Neural Networks*, Perth, Australia, 1995, pp. 1942-1948.
- [17] Y. del Valle, M. Digma, A. Gray, J. Perkel, G. K. Venayagamoorthy, and R. G. Harley, "Enhanced particle swarm optimizer for power system applications," *IEEE Swarm Intelligence Symposium*, St. Louis, MO, USA, September 21-23, 2008.
- [18] J. B. A. London Jr., L. F. C. Alberto, and N. G. Bretas, "Analysis of measurement-set qualitative characteristics for state-estimation purposes," *IET Gener. Transm. Distrib.*, vol. 1, no. 1, pp. 39-45, Jan 2007.
- [19] R. Christie. (1999, August). Power system test archive. [Online]http://www.ee.washington.edu/research/pstc