

QUT Digital Repository:
<http://eprints.qut.edu.au/>



This is the author version published as:

Recker, Jan C. (2010) *Opportunities and constraints : the current struggle with BPMN*. Business Process Management Journal, 16(1). pp. 181-201.

© Copyright 2009 Emerald

Opportunities and Constraints: The Current Struggle with BPMN

Abstract

Purpose – The Business Process Modeling Notation is an increasingly important standard for process modeling and has enjoyed high levels of attention in business practice. In this paper, experiences are shared from several research projects investigating the uptake and user acceptance of BPMN by analysts world-wide. This personal viewpoint offers a number of implications for BPM practice and seeks to stimulate and guide further research and other developments in this area.

Design/methodology/approach – This article offers a personal viewpoint based on the experiences and findings gathered from survey research and interviews on the use of BPMN. While details on research execution are mostly omitted, references are provided to guide the interested reader to the methodology used in the original studies.

Findings – First, statistics are provided on the usage of BPMN by process modelers world-wide. Amongst others, it is shown that the high interest in BPMN has created a massive demand for BPM education and training. Second, a number of usage problems related to the practice of process modeling with BPMN are described and suggestions are provided how organizations have developed workarounds for these problems. Third, it is suggested that BPMN is over-engineered and more insights into practical usage are needed for future development.

Research limitations / implications – While being based on empirical research, a limitation of this paper is the lack of detail about research execution; however, references are provided. The paper offers a personal viewpoint on the state of current and future practice of process modeling and discusses a range of implications for future research.

Practical implications – The paper describes a number of commonly encountered pitfalls when modeling processes with BPMN. It also provides directions for the organizational implementation and future development of process modeling as well as implications for various BPMN stakeholders.

Originality/value – This viewpoint is derived from some of very few empirical studies on the usage of BPMN specifically and BPM standards generally.

Keywords – Process modeling, standards, survey

Paper type – Viewpoint

1. Introduction

Since the first lines were scratched into the dirt, people have been drawing pictures to help them explain things. People understand graphics – be it as part of Google Earth, in their Tom Toms, in software development projects, or in the management of business processes. The graphical specification of business operations and transactions in the form of so-called *process models* is an important tool in the design, re-design, enactment and evaluation of business activities and regularly consumes a considerable amount of resources and time in process management projects (Indulska et al., 2006).

A large number of graphical process modeling languages has been developed to aid organizations in the documentation of their processes. These languages range from simple flowcharting techniques to more advanced languages capable of capturing information required for process simulation and execution. The latest representative from the large camp of process modeling languages has become known under the acronym BPMN – the Business Process Modeling Notation (BPML.org and OMG, 2006). BPMN is a recently published notation standard for business processes. It was developed by an industry consortium (BPML.org), whose constituents represented a wide range of BPM tool vendors but no end users. Although the ‘official’ release date was only February 2006, BPMN has quickly become a de facto standard for graphical process modeling. No other notation has seen such an uptake in such a short time as BPMN has. It is widely supported by both free and commercial process modeling tools (e.g., Pega, Sparxsystems, Telelogic, Intalio, itp-commerce, Tibco, IBM Websphere, Sungard), integrated into the curriculum of education providers (e.g., Widener University, Queensland University of Technology and Howe School of Technology Management), and part of the offerings of modeling coaches and consultants (e.g., Object Training, BPM-Training.com and BPMInstitute.org). Even other standardization bodies (e.g., WfMC) have revised their standard development efforts to incorporate BPMN (Workflow Management Coalition, 2008).

In light of this development, both for scholars studying the phenomenon of BPMN and for the wider community of BPM practitioners, three questions emerge that wait to be answered (Zur Muehlen, 2008b):

1. *How can BPMN be used (i.e., what is theoretically possible)?*
2. *How should BPMN be used (i.e., what is recommended for practice)?*
3. *How is BPMN being used (i.e., what do people actually do with it)?*

A growing body of research has been conducted – and continues to do so – on questions one and two. For instance, research has been published that examines BPMN’s capacity to support workflow technology and domain representations (Recker et al., 2007b), to facilitate semantic script analysis (Dijkman et al., 2008), and how to generate process

(Ouyang et al., 2008a) and software code (Ouyang et al., 2008b) from BPMN. The fundamental question of how BPMN is actually being used, however, has not yet been fully examined. In fact, only a few studies have recently been published that begin to shed light into actual application and usage patterns concerning BPMN, mostly in the form of case studies (e.g., Recker et al., 2007a, Recker et al., 2006a, zur Muehlen and Ho, 2008). There is research on the uptake and use of standards in related areas, such as the work on the adoption of UML in systems development (Dobing and Parsons, 2006, Kobryn, 1999, Siau and Loo, 2006); however it remains unclear how many of these insights apply to the BPM context.

The purpose in writing this paper is three-fold. First, to provide results from one of the very few large-scale studies of BPMN adopters and to deliver insights in the way BPMN is being implemented and used in business practice. Second, based on the experiences gathered in our research on the BPMN uptake over the last three years, to raise a number of implications and questions about the current and future state of research and practice in process modeling. Third, to stimulate future debate and discussion in the process modeling ecosystem of vendors, standardization bodies and end users.

We proceed as follows. The next section briefly introduces process modeling with BPMN and recapitulates the background of the research studies on the basis of which this viewpoint was crafted. Section three describes selected results from a global survey of BPMN adopters conducted in 2007. Section four discusses a number of BPMN usage problems uncovered during our studies. Section five concludes this viewpoint article and suggests a number of pathways for practice, future development, and research in the area of BPMN.

2. Background

A) Process Modeling with BPMN

Process modeling is widely used within organizations as a method to increase awareness and knowledge of business processes, and to deconstruct organizational complexity (Bandara *et al.*, 2005). Process models describe how businesses conduct their operations and typically includes graphical depictions of at least the activities, events/states, and control flow logic that constitute a business process (Curtis et al., 1992). Additionally, process models may also include information regarding the involved data, organizational/IT resources and potentially other artifacts such as external stakeholders and performance metrics to name just a few (e.g., Scheer, 2000).

Process models are designed using so-called process modeling languages (sometimes called notations or techniques), i.e., sets of graphical constructs and rules how to combine these constructs. Existing business process modeling languages fall into two categories (Phalp, 1998). Intuitive graphical modeling languages such as the Event-driven Process Chain (EPC) (Scheer, 2000) are mostly concerned with capturing and understanding processes for project scoping tasks, and for discussing business requirements and process improvement initiatives with subject matter experts. Conversely, other languages such as Petri nets (Petri, 1962) are founded on mathematical, rigorous paradigms. These

techniques are typically used for process analysis (Verbeek *et al.*, 2007) or process execution (van der Aalst and ter Hofstede, 2005), and can also facilitate simulation or experimentation with process scenarios (Hansen, 1996).

In considering 'how to' model business processes, the decision of the type of language to be used for process modeling is an important consideration (Rosemann, 2006). This decision can be seen as essentially the same problem that software engineers encounter when carrying out analysis or design tasks. One might choose to use structured analysis notations, or object-oriented approaches. Different modeling languages tend to emphasize diverse aspects of processes, such as activity sequencing, resource allocation, communications, or organizational responsibilities (Soffer and Wand, 2007). In other words, the Petri net model of a business domain looks considerably different from a data flow diagram or BPMN model of the same domain.

A wide range of process modeling languages has been proposed over time, which – recently – has injected a call for standardization efforts in this field (Davenport, 2005). The development of the Business Process Modeling Notation (BPMN) (BPML.org and OMG, 2006) denotes the answer to this call for standardization. BPMN was developed by an industry consortium, whose constituents represented a wide range of BPM tool vendors that envisaged BPMN to be used in many application areas. These areas span typical process documentation and improvement scenarios to technical applications of process modeling such as workflow engineering, simulation or web service composition.

The standardization process took six years and more than 140 meetings, both physical and virtual. The BPMN working group developed a specification document that differentiates BPMN into a set of core graphical elements and an extended specialized set. The core set was envisaged to suffice for depicting the essence of business processes in intuitive graphical models, while the complete set provides additional constructs to support advanced process modeling concepts such as process orchestration and choreography, workflow specification, event-based decision making and exception handling. Overall, the complete BPMN specification defines 53 constructs plus attributes, grouped into four basic categories of elements, *viz.*, Flow Objects, Connecting Objects, Swimlanes and Artefacts. *Flow Objects*, such as events, activities and gateways, are the most basic elements used to create BPMN models. *Connecting Objects* are used to interconnect Flow Objects through different types of arrows. *Swimlanes* are used to group activities into separate categories for different functional capabilities or responsibilities (e.g., different roles or organizational departments). *Artefacts* may be added to a model where appropriate in order to display further related information such as processed data or other comments. For further information on BPMN refer to (BPML.org and OMG, 2006). Figure 1 gives the example of a BPMN model of a payment process.

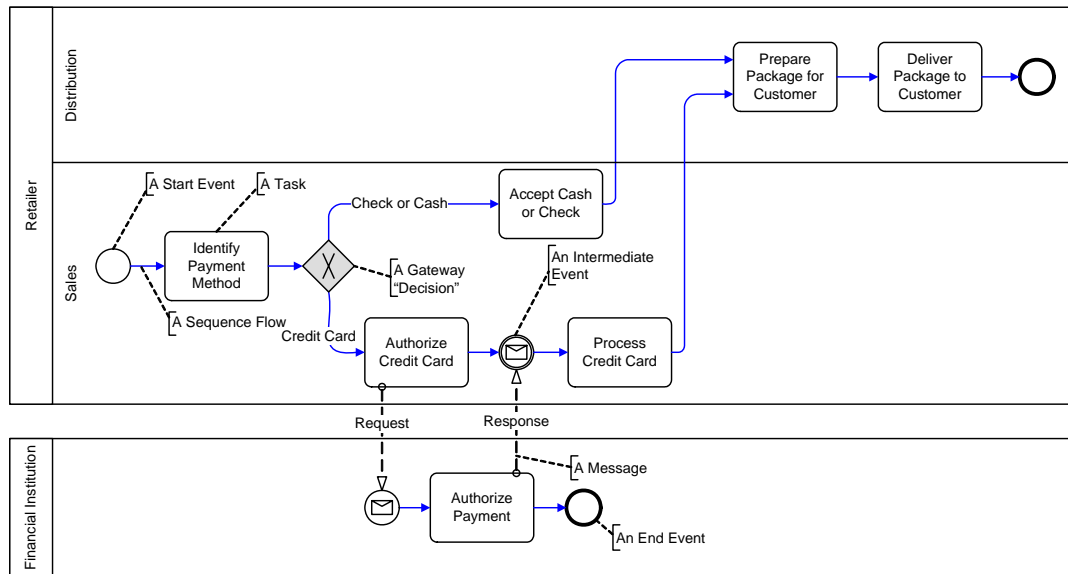

Figure 1. BPMN example 'Payment process'

B) Data Sources and Study Background

This article offers a viewpoint on the current state and future development of BPMN process modeling practice. In doing so, it consolidated experiences and lessons learned from a number of studies we conducted over the last three years on the uptake and usage of BPMN in process modeling practice.

Our original motivation to undertake research on the uptake and use of BPMN was based on the observation that organizations seeking to adopt BPMN were actually shorthanded in terms of experience reports available. Available tutorials were scarce, training programs virtually non-existent and case studies rare. None of these barriers, however, stopped BPMN from its rapid adoption in business practice. The swiftness of this uptake, in turn, motivated us to study the factors explaining adoption, acceptance and use of process modeling in general, and BPMN in particular. More specifically, in our research we investigated three aspects of BPMN:

- What are capabilities and deficiencies of BPMN for process modeling practice?
- Which factors explain the user acceptance of BPMN?
- How is BPMN used in practice?

To that end, over the last three years we launched three programs of research, using three different types of data collection. First, we performed an analysis of the capabilities and deficiencies of BPMN using a theory of representation (Wand and Weber, 1990, 1993, 1995) This theoretical model allows research to gauge, and compare, the expressiveness and complexity of process modeling language based on an analysis of their

representational capabilities. This mode of investigation is known as a representational analysis and is a widely used tool in research on process modeling (e.g., Green and Rosemann, 2000, Green et al., 2005, Recker and Indulska, 2007, Rosemann et al., 2009, Rosemann et al., 2006). Based on our theoretical analysis, we then conducted a range of semi-structured interviews with BPMN adopters to study how deficiencies BPMN were experienced in process modeling practice and how BPMN users implemented work-arounds to mitigate these deficiencies. This type of study can be classified as an exploratory, qualitative theory-driven investigation (Benbasat et al., 1987) using semi-structured interviews as a research method and following the guidelines for qualitative case study and interview research as described in (Yin, 2003) and (Kvale, 1996, Myers and Newman, 2007). In our study, six Australian-based organizations participated as research cases, and a total of nineteen practitioners of these six organizations, incorporating various roles in their respective business environments, (e.g., business analyst, technical analyst, modeling team leader), were interviewed. The participants ranged in terms of their levels of experience with modeling, and with BPMN. In depth-details about design, conduct, and results of this study are available in (Recker et al., 2007a, Recker et al., 2005, 2006a, Recker et al., 2007b).

Second, incorporating the findings from our exploratory study, we studied the factors explaining continued user acceptance of BPMN by developing a theoretical model of the factors influencing the continued usage intention (see Recker, 2007, Recker and Rosemann, 2007a, Recker et al., 2006b) and testing this theory using feedback from 590 BPMN users world-wide. Data collection and theory testing was conducted using cross-sectional survey research, which is the typical way for testing theories and factor models (Pinsonneault and Kraemer, 1993). Design and conduct of the survey research was based on the predominant guidelines for such research (e.g., Grover et al., 1993, King and He, 2005, Malhotra and Grover, 1998, Moore and Benbasat, 1991, Newsted et al., 1998, Umbach, 2004, Zmud and Boynton, 1991). In depth-details about design, conduct, and results of this study are available in (Recker, 2007, 2008a, b, Recker and Rosemann, 2007b, 2008).

Third, in a related stream of research we were interest in how users deploy BPMN in the actual act of creating process models. To that end, we collected a sample of 120 BPMN process models from various organizations, vendors, consultants and trainers and analyzed the usage of BPMN in terms of the symbols used and symbols avoided. We coded each BPMN models as a binary string and performed a range of statistical analyses such as cluster analysis, frequency analysis, covariance analysis and distribution analysis (e.g., Hamming, 1950, Pallant, 2005, Stevens, 2001). In this study we sought to determine the most commonly used set of BPMN symbols and to provide the ecosystem of process modelers with specific advice which elements of BPMN to use when. In depth-details about design, conduct, and results of this study are available in (zur Muehlen and Recker, 2008, zur Muehlen et al., 2007).

Based on the data collected during the studies, the resulting findings, and the experiences and lessons learned from this research, the remainder of this article offers a personal viewpoint on what our research reveals about the current and future state of BPMN

process modeling. To that end, in the following we firstly provide details about what we learned through our world-wide survey about the global community of BPMN modelers.

3. Selected Findings

During our survey study, data was collected from BPMN modelers from over thirty countries world-wide. A requirement for participation was that the respondents should have actively developed process models with BPMN. Hence, the sample frame of interest to the survey included BPMN process modelers, i.e., those who develop BPMN process models (as opposed to individuals who merely are confronted with BPMN models, i.e., model readers).

We received usable responses from 590 BPMN modelers. The geographic distribution of these respondents mirrors the general distribution of BPM practitioners world-wide (e.g., Palmer, 2007, Wolf and Harmon, 2006). Europe, North America and Oceania account for almost three quarters of all responses (see Figure 2). Almost 60% of respondents work for private sector companies. More than 40% of respondents work in large organizations with more than 1000 employees, while 22.7% and 26.8% of respondents work for middle- and small-sized organizations, respectively. The organizational distribution of BPMN modelers closely mirror the survey of BPM practitioners reported in (Wolf and Harmon, 2006), who report a somewhat similar organizational distribution (28%, 33% and 41% respectively for small-, medium- and large-sized organizations). The size of the process modeling team, in which respondents work as process modelers, ranges from less than 10 members (64.4% of respondents) to more than 50 members (3.8% of respondents). This would suggest that, even in large corporations, the team of employees dedicated to BPMN modeling is small.

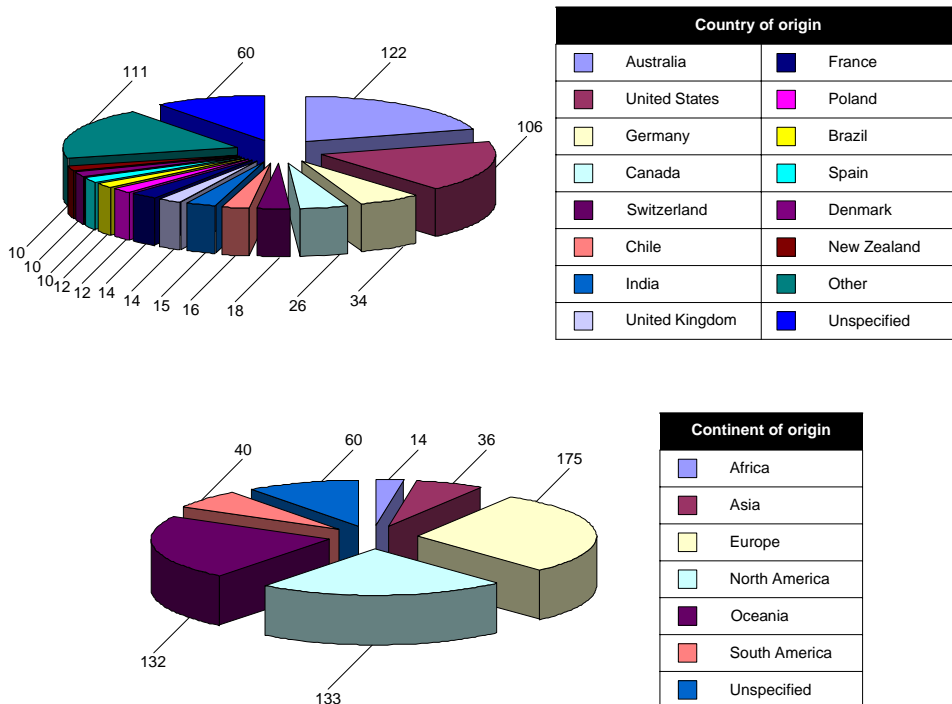

Figure 2. Participant country and continent of origin

Respondents were also asked to comment on the type of training received. Only 13.6% of respondents received formal training in process modeling with BPMN (e.g., by means of a licensed professional training provider or as part of university studies in business process management-related courses). Of those that were trained, certified courses through vendors and training providers appeared to be the most popular options (9.5%), followed by in-house training (5.1%). In contrast, roughly 70% of respondents learned BPMN process modeling through self-education or working on the job.

While levels of training are arguably low, the respondents varied in terms of their experience with process modeling in general, and with BPMN in particular (see Figure 3). The reported average amount of experience in process modeling was 6.4 years (with a median of 5). Experience in BPMN ranged from 15 days to 5 years (with an average of 9 months and a median of 4 months). Interestingly, half of the responses were obtained from process modelers with less than six months experience in BPMN. The limited amount of BPMN experience is most likely due to the recency of its release. While BPMN has been available in version 0.9 since 2002, only since 2004 was it officially released and announced in public. Moreover, BPMN's ratification as an OMG standard was finalized only in 2007.

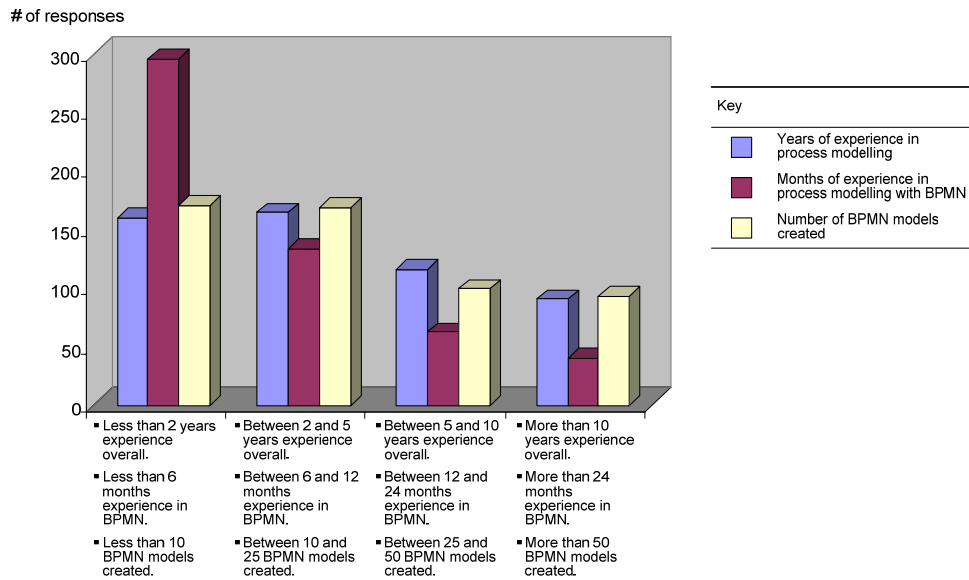

Figure 3. Participant modeling experience

We were further interested in the types of application areas for which BPMN is being used in organizations. Figure 4 shows the most popular purposes for which BPMN is used as per the study participants (note that multiple answers were possible). It would appear that “classical” process management applications such as documentation, redesign, continuous improvement and knowledge management dominate application areas of BPMN, while more technical application areas such as software development, workflow management or process simulation are not (yet) widespread.

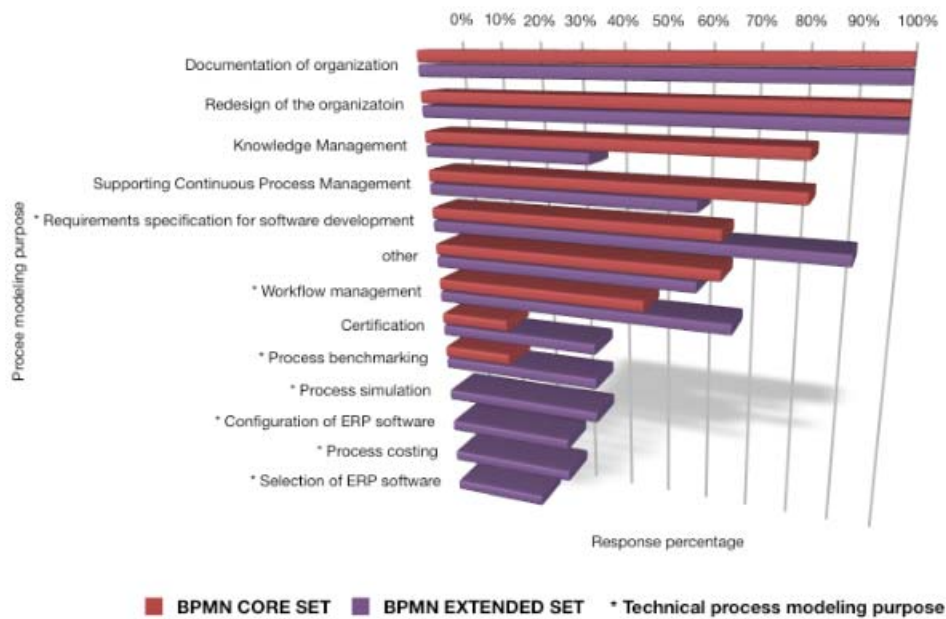

Figure 4. Application areas of BPMN contrasted to extent of symbols use

Figure 4 also shows how the usage of BPMN varies in accordance to the application areas by indicating for which purpose respondents used either the core set of BPMN or an extended or full set. Overall, 32.5% of responded used the BPMN core set only, with a further 33.9% of respondents using the full set of BPMN sets and 23.4% of respondents using an extended but not full set of symbols.

Regarding tool support for BPMN, Table 1 lists the ten most popular tools in use and also the type of functionality that users expect in a BPMN tool. As can be seen, Microsoft Visio denotes by far the most popular way to model BPMN, followed by Itp-Commerce’s solution, which is in a Visio plug-in that extends the modeling capacities of Visio with a BPMN simulation engine, additional attributes and analysis options. Aside from these small-scaled solutions, a number of familiar names appear in Table 1, e.g., SparxSystems, Telelogic, Intalio, IDS Scheer and Casewise. These vendors provide advanced BPM solutions with extended features that stretch beyond pure modeling capabilities. Overall, we notice a fragmented market of tool providers, indicated by the long-tail distribution of tools in use by organizations.

Top Ten Most Popular Tools for Modeling BPMN	Usage
Microsoft Visio	18.2%
itp-Commerce Process Modeler	7.8%
SparxSystems Enterprise Architect	6.9%
Visual Paradigm Visual Architect	6.2%
Telelogic System Architect	5.7%
Intalio BPMS	5.0%
ILOG Jviews	3.8%
IDS Scheer ARIS	3.3%
Casewise Corporate Modeler	3.3%
Holocentric Modeler	2.8%
Most popular tool functionality used	Usage
Integrated repository for all process models	46.4%
Navigation between process models on different levels	56.2%
Additional attribute fields for symbols	42.6%
Access to other notations and modeling techniques	31.7%
Access to new symbols in addition to BPMN symbols	26.4%
Access or hyperlinks to other documentation from within the process models	41.9%
Method filter for restricting and specifying the set of symbols to be used	21.1%

Table 1. BPMN tool support

Perusal of Table 1 further shows that end users make use of extended tool functionality, if available. For instance, BPMN users often use model repositories, model browsers and

similar functionality implemented in modeling tools to support the navigation between large numbers of BPMN models – functionality a basic drawing tool cannot deliver. Also, our research indicates that BPMN models are quite often extended with additional symbols (e.g., to articulate process-related risks, organizational information, performance indicators and the like) or even other models (e.g., organizational charts, business rule specifications, data information or service descriptions). This situation points to BPMN being a pure process modeling language. Users, however, often are concerned with enterprise modeling – the capture of organizational information such as data, resources, risks, documents etc. beyond the mere depiction of the control flow of their business operations. In fact, a lot of organizational tasks require additional information, be it for workflow specification (resources, data, objects etc.) or compliance management (risks, mitigation strategies, process owners etc.).

4. User Problems with BPMN – Room for Improvement

One of the prevalent objectives in our studies of the BPMN uptake and use was to gather insights about the way BPMN is applied for process modeling, and where certain pitfalls and drawbacks exist.

In our study of the factors explaining and predicting user acceptance of BPMN (Recker, 2008b) we found that user acceptance of BPMN is primarily dependent on two factors, *instrumentality* (usefulness and performance of BPMN for process modeling) and *easiness* (complexity of creating BPMN models).

Both instrumentality and easiness, in turn, relate to two main characteristics of any modeling language –expressiveness (can I model everything that I deem required to have depicted in my diagram) and complexity (how cumbersome is it for me to select and specify the graphical constructs in my model?). Answers to these questions can not only provide support to users working with BPMN but also serve as input to future revisions or extensions. And indeed, being an Object Management Group (www.omg.org) standard, BPMN is constantly undergoing revisions and extensions. The updated version BPMN 1.1 was more or less quietly released early 2008, and working groups have already been formed to work on BPMN 2.0, which will come out some years into the future.

In light of this ongoing development, our endeavor was accordingly to gather feedback from end users, not on the strengths of BPMN but instead on its weaknesses – where future releases of BPMN can be improved. The following collection is a consolidated list of user responses we gathered about the *issues* of modeling with BPMN. Hopefully, these user issues serve as a starting point, not only for the BPMN developers but also for tool vendors, consultants, modeling coaches and all those who want to identify – and avoid – obstacles when using BPMN for process modeling.

A) Support for Business Rule Specification

In our theoretical analysis of BPMN on basis of representation theory (Recker et al., 2005), we uncovered that BPMN has a deficit in supporting the articulation of business rules. Both the semi-structured interviews (Recker et al., 2006a) and the global survey

(Recker, 2008b) then confirmed this proposition, as the results from both studies suggest that users in practice indeed have a need to specify business rules in their process models, and feel that they are unable to do so adequately with BPMN.

Process modeling and rule modeling languages are both used in organizations to document organizational policies and procedures. Indeed, business rule specification is an essential task in understanding business processes; yet, at present, users have trouble identifying the interface between process modeling and business rule modeling, and expect better support in the identification of appropriate interfaces between process logic and business rule logic in a process model. Such support could, as one respondent in our interview study put it, be as simple as an additional graphical symbol:

“[...] A symbol that says something specifically is a business rule so that you know in future to look at it, mightn’t be bad.” (interview transcription data)

Some of the workarounds used in practice include narrative descriptions of rules and conditions, using spreadsheets and external tables, and using additional tools that allow users to create hyperlinks to documents, meta-tags and attribute fields (as shown in the example given in Figure 5). Our study results suggest, however, that these workarounds are deemed problematic in practice. Indeed, users perceive a need for graphical support in process modeling languages to assist in the identification and specification of interfaces between process models and the business rules that govern the execution of these processes. Unfortunately, as of today, neither process modeling solutions (such as BPMN) nor business rule specification solutions (such as SBVR) provide this support.

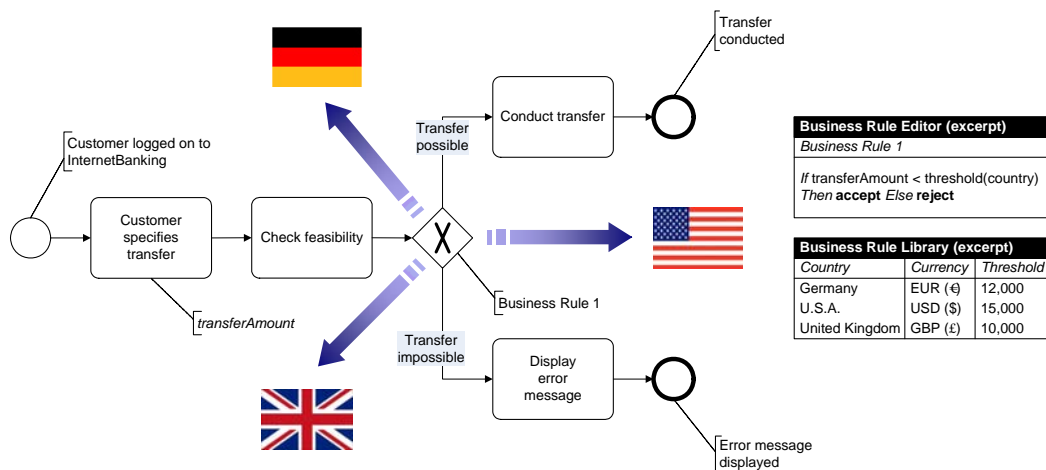

Figure 5. BPMN models and business rules

B) Support for Process Decomposition

A similar situation was found in regard to the articulation of process structure and decomposition. Again, in our theoretical analysis of BPMN with the help representation theory (Recker et al., 2005), we suggested that there are deficits in BPMN as to the precise articulation of the scope and boundaries of the process being modeled. Both interview responses (Recker et al., 2006a), as well as the survey responses (Recker, 2008b) confirmed this proposition.

In other words, BPMN clearly lacks advanced concepts to support tasks related to process decomposition. Some of the respondents clearly suggested that a more explicit graphical representation for process structure and decomposition should indeed be on the agenda for a revision of BPMN:

“[...]I think if the standard allows for a large amount of decomposition, my understanding is that it doesn't at the moment, but if, the people see it as that's the way they want to use it, we definitely need something to link the two [...]. Because it's designed the way it is, we're not supposed to use it that much, but I know some people have that need.” (interview transcription data)

What can be done? In other modeling domains, there are a number of approaches available for functional (Balabko et al., 2005) or object-oriented decomposition (Burton-Jones and Meso, 2006), which could potentially be leveraged for process decomposition. A different, easier approach would be to provide dedicated symbols for placing a process into its organizational and hierarchical context. Event-driven Process Chains (Scheer, 2000), for instance, support process decomposition on a conceptual level with certain annotations to graphical constructs, which indicate process interfaces, process refinements as well as hierarchical levels. The ongoing revision of BPMN should address this limitation to rectify this impediment to user acceptance.

C) Support for Organizational Modeling

Pools and Lanes often present a burden for BPMN users. As per specification, the constructs were envisaged by the BPMN designers to be flexible in interpretation and usage. However, the ambiguity that comes with their flexible semantics is contradictory to the ease with which Lanes and Pools can be used for BPMN modeling.

Our interviews show that 85 percent and 64 percent, respectively, of BPMN users apply at least two or more distinct purposes or meanings to the Pool and Lane symbols in their modeling. The types of purposes used for the Lane construct include, inter alia, roles (used by 61 percent of respondents), organizational units and business areas (39 percent), scoping (22 percent) and grouping (17 percent). In terms of the Pool construct, reported purposes include external organizational units and business areas (64 percent), internal organization (50 percent), scoping (29 percent), and grouping (21 percent).

The global survey then confirmed that the extra effort required for specifying the meaning of a Lane or Pool significantly diminishes the ease with which BPMN models can be built or interpreted (Recker, 2008b). This situation was also present in the interviews:

“[...] we sometimes use it at an organisational level. Sometimes we use it as a business level, sometimes we use it as sector level, it's not really consistent, because of the nature of the symbol.” (interview transcription data)

A related advice would be to provide better support for differentiating the multiple purposes for which Lanes and Pools can be used (e.g., by adding different graphical markers for systems, roles, departments etc.). A different pathway would be to deliberately restrict the meaning of these constructs to provide more specific guidance about the context in which these constructs should be used in a model.

D) Gateways, Off-page connectors and Groups

As reported above, in addition to interviews and surveys, we also collected a large sample of BPMN to ascertain whether all, or how many, of the available BPMN symbols are actually used in practice. BPMN contains about 50 constructs, some of which we found to be less frequently used than others (zur Muehlen and Recker, 2008). Our theoretical analysis (Recker et al., 2005) predicted a number of BPMN symbols to be superfluous and unnecessary. Why do you need an off-page connector? Or the Grouping symbol? Should people use the empty gateway or the empty event symbol super types when there are so many sub types? Is the Multiple Instances concept important to process modeling practice?

To answer these questions, in our study (zur Muehlen and Recker, 2008), we analyzed the frequency of occurrence of the different BPMN constructs in our sample of 120 BPMN models. Based on the frequency distribution, we can suggest the following differentiation of constructs into core, specialist set and overhead as shown in Figure 6.

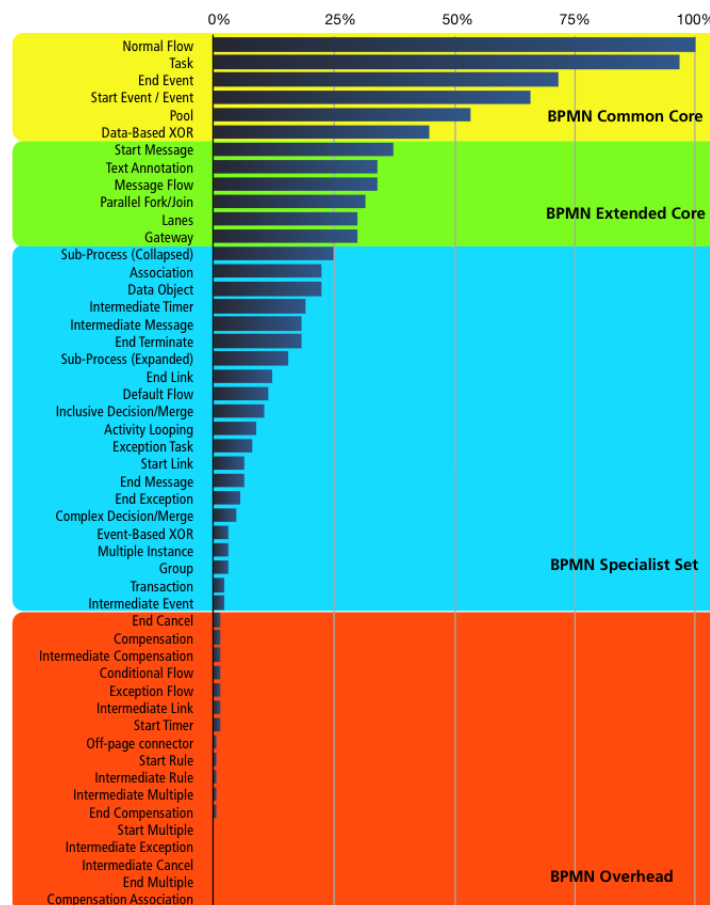

Figure 6. Frequency distribution of BPMN construct usage

Our results suggest that there is a core of BPMN symbols that is most frequently used for the simple documentation of organizational processes. The extended core of BPMN (as per Figure 6) provides advanced concepts that can be used to refine these basic models,

most notable in the area of inter-organizational collaboration and process choreography (as indicated by the symbols ‘Message Flow’, ‘Lane’, and ‘Start Message’. Much less frequently used, is a further set of advanced concepts, pertaining to the modeling of both process choreography and orchestration. Our study suggests that this level of advanced BPMN modeling is done by few specialist process designers, who probably take the basic models as input to make the BPMN models fit for advanced application areas such as workflow engineering, systems specification or process simulation.

E) Events, Events, Events, Events

The last area of concern with BPMN is related to the sheer abundance of different event constructs in BPMN. Similar to the other weaknesses, we predicted on basis of our theoretical analysis of BPMN (Recker et al., 2005) that end users would struggle with the differentiation of BPMN event symbols into various time and type dimensions. Our global survey confirmed then that, from a user perspective, this variety is in fact overwhelming rather than helpful. The study in (Recker, 2008b) reports that users associate a significantly decreased ease of use with BPMN when confronted with multiple event types. This finding suggests that in the case of BPMN the ease of use of process modeling is sacrificed for sheer expressive power. The complexity that comes with selecting the ‘right’ event construct to use in a given process scenario points to a very basic design advice on basis of the user feedback: the simpler the better. And in fact, our study of BPMN models confirms that in practice of all the different event types, only the symbols ‘Start Event’, ‘End Event’, ‘Start Message’, ‘Intermediate Message’ and ‘Intermediate Timer’ are somewhat frequently (i.e., in 20% or more cases).

This situation suggests that it would be important for the BPMN designers to acknowledge this very selective usage of event types in practice. The ongoing revision of BPMN, especially the current BPMN 1.1 draft, however, appears not to take this finding in account. In fact, BPMN 1.1 (OMG, 2008) extends the already excessive list of event constructs with more differentiated sub types, for instance, by differentiating event ‘throwing’ and ‘catching’, and by introducing dedicated signal handlers.

5. Conclusions

A) Contributions

BPMN has become the de facto standard for process modeling. It is indeed a rich and expressive but also complex language to use for the tasks associated with process modeling. And similar to other developments in related areas – think of the case of the UML standard, for instance (Kobryn, 1999) – a great deal of research and development progresses without considering one important question, that of how BPMN is actually being used in practice.

This viewpoint reported on the experiences gathered from a range of empirical research projects aimed at gathering insights into the actual use of the BPMN standard for process modeling in industry practice. Based on our studies of (1) the deficiencies of BPMN for process modeling (Recker et al., 2005, 2006a), (2) the factors explaining user acceptance of BPMN (Recker, 2007, 2008b), and (3) the actual use of BPMN (zur Muehlen and Recker, 2008, zur Muehlen et al., 2007), this viewpoint discussed both statistics about the

uptake of BPMN in industry as well as some of the current modeling issues faced by BPMN end users.

B) Implications for Practice

We believe that this viewpoint article is of interest to the whole process modeling ecosystem, i.e., for developers, vendors, consultants, coaches, project sponsors as well as end users:

End users mostly apply BPMN for purposes similar to what analysts did ten, twenty years ago with flowcharting techniques – they want to describe their operations in simple, graphical terms. The process modeling efforts in most organizations at this stage are simply not at such an advanced or mature stage where they could fully benefit from the full expressiveness of BPMN, for instance, in the area of service-enabled workflow specification or exception handling. A number of implications arise from this observation for end users, coaches and vendors alike:¹

First, the large number of autodidacts and the small share of adequately trained BPMN modelers imply a dearth of advanced BPMN process modeling skills. Such skills, however, are key to ensuring quality and overall success of BPM initiatives. Process modeling is an essential cornerstone in the initial capture and documentation of existing business processes as well as in the specification of re-designed, automated or otherwise changed processes. The cost of fixing errors made in the conceptual specification of processes (due to lacking expertise in process modeling, for instance) are a very costly impediment to BPM project success (Lauesen and Vinter, 2001) and thereby to sustained engagement and commitment to the BPM philosophy in organizations. Also, the fact that roughly 70% of BPMN users are self-taught implies the tremendous danger that idiosyncratic ways of using BPMN become wide-spread. This situation will then lead to a BPM modeling community that will be too fragmented and far away from sound practices when universally accepted standards and guidelines become available.

However, the lack of advanced BPMN process modeling skills also presents considerable opportunities for education providers – be it universities, consultants or training providers – to address this gap. There are hopeful signs in these communities. Many universities have started to adopt BPM and process modeling courses in their curriculum (zur Muehlen, 2008a). Over time, this movement will lead to a market of graduates in IT or business equipped with process management and modeling skills. Similarly, training providers have emerged over the last one or two years that offer corporate or individual certification courses on the usage of BPMN. Some of these training providers (such as Bruce Silver, see <http://69.36.189.101/wordpress/>), are in regular close contact with academia, which is a hopeful and positive sign for the future of process modeling.

Second, the reported problems regarding the use of BPMN symbols, such as the ambiguous specification of Lanes and Pools, or the provision of multiple event types,

¹ These implications are also blogged under <http://www.bpm-research.com> and the interested reader is encouraged to read the blog entry and the many responses and comments received from various readers.

should be taken into consideration when providing training or education in BPMN. Most BPMN courses introduce the full BPMN specification to large number of stakeholders. Our research shows, however, that most of this training is in fact only applicable to a small number of BPMN application areas. So we have to ask: Are there any tailored BPMN training programs? What should the 'BPMN beginner' course look like and how can this body of knowledge then be extended by specialist courses? A related advice would indeed be to start with the set of BPMN symbols that in fact are widely used in practice (see Figure 6). This would allow BPMN beginners to instantly be able to grasp, understand and use the majority of models in practice. Sure, she would not yet be an expert, sure she would not yet have learned about the benefits and expressive power of advanced BPMN. But she can go out and leverage the knowledge instantly and make contributions without having to digest the complexity of a full-blown course.

Third, this viewpoint suggests that tool vendors should or could rely more on empirical information about BPMN use when having to make trade-off decisions in BPMN support. Many BPM systems do not support the full set of BPMN constructs. This makes sense, because if the system does not have the capability to execute the semantics of a specific construct (say, a transaction around a set of activities) then it would not make sense to allow a system analyst to draw this construct in the modeling of a process. So which constructs can a vendor neglect initially and which need to be supported? We would argue that it is of best interest to vendors to focus on those constructs heavily used in practice. This approach would give them access to the widest share of the market. Of course, over time, full support should be given, similar to the imperative that BPMN users should over time learn the advanced features of BPMN. But organizations and tool vendors alike often face a need to achieve results very fast. Which also means that releases are built and deployed that are far from finished.

Overall, our findings suggest that the market of tool solutions appears to be still in its formative stages, and will require future consolidation. This is because the current fragmentation of tool solutions implies a number of shortcomings and obstacles for organizations engaging in BPM initiatives. At current, BPMN implementations differ widely – in terms of constructs supported, semantics implemented or additional features provided. This puts extra burdens on the end users, for instance in the scenario of process integration and process model consolidation in the context of inter-organizational process standardization projects or business mergers and acquisitions.

Fourth, our discussion of usage problems raises the question whether a highly expressive but also very complex notation is a desirable result of a standardization process. More than 120 people participated in more than 120 interactions as part of the development effort that went into BPMN 1.0. Unfortunately, very little effort was dedicated to understanding the end user perspective of standards making. The results discussed in this paper show some of the problems impeding usability of BPMN. This situation is a clear call for standardization bodies to take these findings into account to produce standards that are not only technically sound but also likeable and manageable by those envisaged to use them.

Fifth, for end users, this viewpoint article provides an overview of the most commonly faced problems in modeling processes with BPMN, as well as a discussion of the most

commonly used practices in BPMN modeling. Thereby, this article provides guidance to organizations adopting BPMN by giving validated evidence of the BPMN modeling issues that modelers should be aware of. For example, knowing that BPMN exhibits a limitation in the modeling of business rules, an organization may put in place additional tools together with a set of business rule modeling conventions, or it may even adopt a business rule modeling technique. Such a move would help ensure consistent modeling and prevent correcting the models at a later stage. Similarly, by highlighting common practices of BPMN modeling, end users can be guided in their selection of BPMN symbols as well as the most typical ways and procedures by which BPMN can be applied. For instance, the reported usage of extended tool functionality implies that BPM practitioners seek additional support in their process modeling that BPMN cannot provide. This could be a motivating sign for extensions or future revisions to BPMN to provide additional support for application areas (such as compliance management, simulation, ERP software selection, or organizational re-engineering) in which BPMN does not yet provide adequate modeling support. On the other hand, the findings can serve as a starting point for selecting adequate BPM tools for process modeling initiatives in that they provide a set of key features that should be provided by an adequate tool.

C) Implications for Future Research

This viewpoint article suggests a number of implications for future research on the development, uptake and/or use of BPMN. Most notably, the highlighted deficits of BPMN, for instance, in the specification of business rules or the support for process decomposition, can trigger a number of related design science efforts (Hevner et al., 2004) to improve and extend BPMN. For instance, we would like to point out the need for more research on the relationship of process modeling and business rule representations, and the integration between the two approaches. Our study shows that it is evident that BPMN users would prefer to be able to describe representationally in their process models where and how business rules affect the depicted processes, and they have trouble with identifying the interface between process modeling and business rule modeling. Similarly, process decomposition is a vital element in large-scale BPM initiatives. BPMN at current provides only limited support for breaking down complex scenarios into smaller, manageable models. Future research could, for instance, leverage the principles of good decomposition stipulated by representation theory (Burton-Jones and Meso, 2006, Wand and Weber, 1990), to design better BPMN support for large-scale process initiatives.

Regarding research on the uptake and use of BPMN, there are a number of unanswered questions remaining, including: What types of processes are modeled by BPMN users and to what extent does BPMN support the different modeling application areas and styles? What are typical BPMN modeling patterns? Does BPMN support general process or workflow modeling patterns? How good is BPMN in the context of process improvement or knowledge management? What is required to make BPMN models fit for simulation?

To that end, having reflected upon the original three questions about BPMN (see Section 1), in looking forward it sounds only logical to add a fourth question:

How would people like to use BPMN (i.e., what are customer requirements)?

Clearly, this question has not yet been approached. However, given the demand-driven, customer-oriented world of service and product provision that we live in, it seems only natural to believe that standards makers, vendors, coaches and academics alike will, sooner or later, have to pause to consider this very question. Otherwise BPMN goes down a path that many other suggested industry standards have ventured along before. Who still remembers Betamax or Laserdiscs?

Acknowledgments

An earlier, preliminary version of this article has been published in the online magazine BPTrends in May 2008. This personal viewpoint draws on experiences gathered from research conducted in a team of academics. The contributions of Dr Michael Rosemann, Dr Marta Indulska, Dr Peter Green and Dr zur Muehlen have been invaluable and I would like to express my enormous gratitude towards their efforts.

References

- BALABKO, P., WEGMANN, A., RUPPEN, A. & CLÉMENT, N. (2005) Capturing Design Rationale with Functional Decomposition of Roles in Business Processes Modeling. *Software Process: Improvement and Practice*, 10, 379-392.
- BANDARA, W., GABLE, G. G. & ROSEMAN, M. (2005) Factors and Measures of Business Process Modelling: Model Building Through a Multiple Case Study. *European Journal of Information Systems*, 14, 347-360.
- BENBASAT, I., GOLDSTEIN, D. K. & MEAD, M. (1987) The Case Research Strategy in Studies of Information Systems. *MIS Quarterly*, 11, 369-388.
- BPMI.ORG & OMG (2006) Business Process Modeling Notation Specification. Final Adopted Specification. Object Management Group.
- BURTON-JONES, A. & MESO, P. (2006) Conceptualizing Systems for Understanding: An Empirical Test of Decomposition Principles in Object-Oriented Analysis. *Information Systems Research*, 17, 38-60.
- CURTIS, B., KELLNER, M. I. & OVER, J. (1992) Process Modeling. *Communications of the ACM*, 35, 75-90.
- DAVENPORT, T. H. (2005) The Coming Commoditization of Processes. *Harvard Business Review*, 83, 100-108.
- DIJKMAN, R. M., DUMAS, M. & OUYANG, C. (2008) Semantics and Analysis of Business Process Models in BPMN. *Information and Software Technology*, In Press.
- DOBING, B. & PARSONS, J. (2006) How UML is Used. *Communications of the ACM*, 49, 109-113.
- GREEN, P. & ROSEMAN, M. (2000) Integrated Process Modeling. An Ontological Evaluation. *Information Systems*, 25, 73-87.

- GREEN, P., ROSEMAN, M. & INDULSKA, M. (2005) Ontological Evaluation of Enterprise Systems Interoperability Using ebXML. *IEEE Transactions on Knowledge and Data Engineering*, 17, 713-725.
- GROVER, V., LEE, C. C. & DURAND, D. (1993) Analyzing Methodological Rigor of MIS Survey Research from 1980-1989. *Information & Management*, 24, 305-317.
- HAMMING, R. W. (1950) Error Detecting and Error Correcting Codes. *Bell System Technical Journal*, 26, 147-160.
- HANSEN, G. A. (1996) Simulating Software Development Processes. *Computer*, 29, 73-77.
- HEVNER, A. R., MARCH, S. T., PARK, J. & RAM, S. (2004) Design Science in Information Systems Research. *MIS Quarterly*, 28, 75-105.
- INDULSKA, M., CHONG, S., BANDARA, W., SADIQ, S. & ROSEMAN, M. (2006) Major Issues in Business Process Management: An Australian Perspective. IN SPENCER, S. & JENKINS, A. (Eds.) *17th Australasian Conference on Information Systems*. Adelaide, Australia, Australasian Association for Information Systems.
- KING, W. R. & HE, J. (2005) External Validity in IS Survey Research. *Communications of the Association for Information Systems*, 16, 880-894.
- KOBYRN, C. (1999) UML 2001: A Standardization Odyssey. *Communications of the ACM*, 42, 29-37.
- KVALE, S. (1996) *Inter Views: Introduction to Qualitative Research Interviewing*, Thousand Oaks, California, Sage.
- LAUESEN, S. & VINTER, O. (2001) Preventing Requirement Defects: An Experiment in Process Improvement. *Requirements Engineering*, 6, 37-50.
- MALHOTRA, M. K. & GROVER, V. (1998) An Assessment of Survey Research in POM: From Constructs to Theory. *Journal of Operations Management*, 16, 407-425.
- MOORE, G. C. & BENBASAT, I. (1991) Development of an Instrument to Measure the Perceptions of Adopting an Information Technology Innovation. *Information Systems Research*, 2, 192-222.
- MYERS, M. D. & NEWMAN, M. (2007) The Qualitative Interview in IS Research: Examining the Craft. *Information and Organization*, 17, 2-26.
- NEWSTED, P. R., HUFF, S. L. & MUNRO, M. (1998) Survey Instruments in Information Systems. *MIS Quarterly*, 22, 553-554.
- OMG (2008) Business Process Modeling Notation, V1.1. Object Management Group.
- OUYANG, C., DUMAS, M., TER HOFSTED, A. H. M. & VAN DER AALST, W. M. P. (2008a) Pattern-based Translation of BPMN Process Models to BPEL Web Services. *International Journal of Web Services Research*, 5, 42-61.
- OUYANG, C., VAN DER AALST, W. M. P., DUMAS, M., TER HOFSTED, A. H. M. & MENDLING, J. (2008b) From Business Process Models to Process-Oriented Software Systems. *ACM Transactions on Software Engineering Methodology*, forthcoming, In Press.
- PALLANT, J. F. (2005) *SPSS Survival Manual: A Step By Step Guide to Data Analysis Using SPSS for Windows (Version 12)*, Crows Nest, Australia, Allen & Unwin.
- PALMER, N. (2007) A Survey of Business Process Initiatives. BPTrends.

- PETRI, C. A. (1962) Fundamentals of a Theory of Asynchronous Information Flow. IN POPPLEWELL, C. M. (Ed.) *IFIP Congress 62: Information Processing*. Munich, Germany, North-Holland.
- PHALP, K. T. (1998) The CAP Framework for Business Process Modelling. *Information and Software Technology*, 40, 731-744.
- PINSONNEAULT, A. & KRAEMER, K. L. (1993) Survey Research Methodology in Management Information Systems: An Assessment. *Journal of Management Information Systems*, 10, 75-105.
- RECKER, J. (2007) Why Do We Keep Using A Process Modelling Technique? IN TOLEMAN, M., CATER-STEEL, A. & ROBERTS, D. (Eds.) *18th Australasian Conference on Information Systems*. Toowoomba, Australia, The University of Southern Queensland.
- RECKER, J. (2008a) BPMN Modeling - Who, Where, How and Why. *BPTrends*, 5, 1-8.
- RECKER, J. (2008b) Understanding Process Modelling Grammar Continuance: A Study of the Consequences of Representational Capabilities. *Faculty of Information Technology*. Brisbane, Australia, Queensland University of Technology.
- RECKER, J. & INDULSKA, M. (2007) An Ontology-Based Evaluation of Process Modeling with Petri Nets. *Journal of Interoperability in Business Information Systems*, 2, 45-64.
- RECKER, J., INDULSKA, M. & GREEN, P. (2007a) Extending Representational Analysis: BPMN User and Developer Perspectives. IN ALONSO, G., DADAM, P. & ROSEMAN, M. (Eds.) *Business Process Management - BPM 2007*. Brisbane, Australia, Springer.
- RECKER, J., INDULSKA, M., ROSEMAN, M. & GREEN, P. (2005) Do Process Modelling Techniques Get Better? A Comparative Ontological Analysis of BPMN. IN CAMPBELL, B., UNDERWOOD, J. & BUNKER, D. (Eds.) *16th Australasian Conference on Information Systems*. Sydney, Australia, Australasian Chapter of the Association for Information Systems.
- RECKER, J., INDULSKA, M., ROSEMAN, M. & GREEN, P. (2006a) How Good is BPMN Really? Insights from Theory and Practice. IN LJUNGBERG, J. & ANDERSSON, M. (Eds.) *14th European Conference on Information Systems*. Goeteborg, Sweden, Association for Information Systems.
- RECKER, J. & ROSEMAN, M. (2007a) Integration of Models for Understanding Continuance of Process Modeling Techniques. *13th Americas Conference on Information Systems*. Keystone, Colorado, Association for Information Systems.
- RECKER, J. & ROSEMAN, M. (2007b) Understanding the Process of Constructing Scales Inventories in the Process Modelling Domain. IN ÖSTERLE, H., SCHELP, J. & WINTER, R. (Eds.) *15th European Conference on Information Systems*. St. Gallen, Switzerland, University of St. Gallen.
- RECKER, J. & ROSEMAN, M. (2008) Measuring Perceived Representational Deficiencies in Conceptual Modeling: Instrument Development and Test. IN BOLAND, R. J., LIMAYEM, M. & PENTLAND, B. T. (Eds.) *29th International Conference on Information Systems*. Paris, France, Association for Information Systems.
- RECKER, J., ROSEMAN, M., GREEN, P. & INDULSKA, M. (2006b) Extending the Scope of Representation Theory: A Review and a Proposed Research Model. IN

- GREGOR, S. & HART, D. (Eds.) *3rd Biannual ANU Workshop on Information Systems Foundations*. Canberra, Australia, ANU E Press.
- RECKER, J., ROSEMANN, M. & KROGSTIE, J. (2007b) Ontology- versus Pattern-based Evaluation of Process Modeling Languages: A Comparison. *Communications of the Association for Information Systems*, 20, 774-799.
- ROSEMANN, M. (2006) Potential Pitfalls of Process Modeling: Part A. *Business Process Management Journal*, 12, 249-254.
- ROSEMANN, M., GREEN, P., INDULSKA, M. & RECKER, J. (2009) Using Ontology for the Representational Analysis of Process Modeling Techniques. *International Journal of Business Process Integration and Management*, In Press.
- ROSEMANN, M., RECKER, J., INDULSKA, M. & GREEN, P. (2006) A Study of the Evolution of the Representational Capabilities of Process Modeling Grammars. IN DUBOIS, E. & POHL, K. (Eds.) *Advanced Information Systems Engineering - CAiSE 2006*. Luxembourg, Grand-Duchy of Luxembourg, Springer.
- SCHEER, A.-W. (2000) *ARIS - Business Process Modeling*, Berlin, Germany, Springer.
- SIAU, K. & LOO, P.-P. (2006) Identifying Difficulties in Learning UML. *Information Systems Management*, 23, 43-51.
- SOFFER, P. & WAND, Y. (2007) Goal-Driven Multi-Process Analysis. *Journal of the Association for Information Systems*, 8, 175-202.
- STEVENS, J. P. (2001) *Applied Multivariate Statistics for the Social Sciences*, Hillsdale, New Jersey, Lawrence Erlbaum Associates.
- UMBACH, P. D. (2004) Web Surveys: Best Practices. *New Directions for Institutional Research*, 2004, 23-38.
- VAN DER AALST, W. M. P. & TER HOFSTEDE, A. H. M. (2005) YAWL: Yet Another Workflow Language. *Information Systems*, 30, 245-275.
- VERBEEK, H. M. V., VAN DER AALST, W. M. P. & TER HOFSTEDE, A. H. M. (2007) Verifying Workflows with Cancellation Regions and OR-joins: An Approach Based on Relaxed Soundness and Invariants. *The Computer Journal*, 50, 294-314.
- WAND, Y. & WEBER, R. (1990) An Ontological Model of an Information System. *IEEE Transactions on Software Engineering*, 16, 1282-1292.
- WAND, Y. & WEBER, R. (1993) On the Ontological Expressiveness of Information Systems Analysis and Design Grammars. *Journal of Information Systems*, 3, 217-237.
- WAND, Y. & WEBER, R. (1995) On the Deep Structure of Information Systems. *Information Systems Journal*, 5, 203-223.
- WOLF, C. & HARMON, P. (2006) *The State of Business Process Management - 2006*, www.BPTrends.com.
- WORKFLOW MANAGEMENT COALITION (2008) Workflow Management Coalition Workflow Standard. Process Definition Interface -- XML Process Definition Language. Document Number WFMC-TC-1025. WfMC.
- YIN, R. K. (2003) *Case Study Research: Design and Methods*, Thousand Oaks, California, Sage Publications.
- ZMUD, R. W. & BOYNTON, A. C. (1991) Survey Measures and Instruments in MIS: Inventory and Appraisal. IN KRAEMER, K. L. (Ed.) *The Information Systems*

- Research Challenge: Survey Research Methods*. Boston, Massachusetts, Harvard Business School.
- ZUR MUEHLEN, M. (2008a) Class Notes: BPM Research and Education - A Little Knowledge is a Dangerous Thing. *BPTrends*, 5, 1-5.
- ZUR MUEHLEN, M. (2008b) Class Notes: BPM Research and Education - Evidence-Based Research - What We Know, What We Don't and Why We Should Find Out. *BPTrends*, 5, 1-6.
- ZUR MUEHLEN, M. & HO, D. T.-Y. (2008) Service Process Innovation: A Case Study of BPMN in Practice. IN SPRAGUE JR, R. H. (Ed.) *41th Annual Hawaii International Conference on System Sciences*. Waikoloa, Hawaii, IEEE.
- ZUR MUEHLEN, M. & RECKER, J. (2008) How Much Language is Enough? Theoretical and Practical Use of the Business Process Modeling Notation. IN LÉONARD, M. & BELLAHSÈNE, Z. (Eds.) *Advanced Information Systems Engineering - CAiSE 2008*. Montpellier, France, Springer.
- ZUR MUEHLEN, M., RECKER, J. & INDULSKA, M. (2007) Sometimes Less is More: Are Process Modeling Languages Overly Complex? IN TAVETER, K. & GASEVIC, D. (Eds.) *11th International IEEE EDOC Conference Workshop*. Baltimore, Maryland, IEEE.