



This is the authors' version of the following journal article:

[Aldred, Lachlan](#), [van der Aalst, Wil M. P.](#), [Dumas, Marlon](#), & [ter Hofstede, Arthur H. M.](#) (2009) Dimensions of coupling in middleware. *Concurrency and Computation: Practice and Experience*, 21(18), pp. 2233-2269.

# Dimensions of Coupling in Middleware

Lachlan Aldred<sup>1</sup>, Wil M.P. van der Aalst<sup>1,2</sup>, Marlon Dumas<sup>1</sup>, and Arthur H.M. ter Hofstede<sup>1</sup>

<sup>1</sup> Faculty of IT, Queensland University of Technology, Australia

<sup>2</sup> Department of Mathematics and Computer Science, Eindhoven University of Technology, The Netherlands

**Abstract.** It is well accepted that different types of distributed architectures require different degrees of coupling. For example, in client-server and three-tier architectures, application components are generally tightly coupled, both with one-another and with the underlying middleware. Meanwhile, in off-line transaction processing, grid computing and mobile applications, the degree of coupling between application components and with the underlying middleware needs to be minimised. Terms such as “synchronous”, “asynchronous”, “blocking”, “non-blocking”, “directed”, and “non-directed” are often used to refer to the degree of coupling required by an architecture or provided by a middleware. However, these terms are used with various connotations. And while various informal definitions have been provided, there is a lack of an overarching formal framework to unambiguously communicate architectural requirements with respect to (de-)coupling. This article addresses this gap by: (i) formally defining three dimensions of (de-)coupling; (ii) relating these dimensions to existing middleware; and (iii) proposing notational elements to represent various coupling integration patterns. This article also discusses a prototype that demonstrates the feasibility of its implementation.

**Keywords:** Distributed architecture, Coupling, Decoupling, Asynchronous/synchronous communication, Message-Oriented Middleware

## 1 Introduction

Modern approaches to integrating distributed systems almost invariably rely on middleware. These middleware take many forms, ranging from distributed object brokers, to message-oriented middleware and enterprise service buses. Each family of middleware is designed to provide proven solutions to a certain set of distributed system integration issues, but how can one compare their relative strengths and weaknesses when they are so different at the core? Indeed, a unified framework for middleware remains elusive.

The heterogeneity of contemporary middleware reflects the absence of a consensus on the right set of communication abstractions to integrate distributed applications [1]. This lack of consensus can be observed even for the most elementary communication primitives, namely send and receive. For example in sending a message, the semantics of what happens (a) if it doesn't arrive, or (b) if it gets buffered (and if so if this happens locally/remotely); is usually not clear until the choice a technology has been made. As noted by Cypher & Leu: “the interactions between the different properties of the send and receive primitives can be extremely complex, and ... the precise semantics of these primitives are not well understood” [2]. Coupling, or the way in which endpoints are connected, lies at the heart of this issue.

The style of coupling can vary from one family of middleware to another. For instance solutions inspired by CORBA [3] use the Remote Procedure Call (RPC) paradigm, wherein the sender and receiver applications typically become synchronised at the thread level. Conversely Message-Oriented Middleware (MOM) solutions use what is usually referred to as an asynchronous approach. In spite of these differences there are MOM implementations supporting request-response, e.g. Java Message Service (JMS) [4], and there are RPC solutions supporting asynchronous interactions. While this sounds encouraging it doesn't mean that these solutions are interchangeable at the conceptual level. Consequently, conceptual comparisons become mired in technical detail. It is one of the goals of this paper to *decouple* conceptual comparisons from technical ones - at least when it comes to inter-coupling.

A full analysis of middleware would be a daunting task. The set of features is large, particularly when one considers, for example privacy, non-repudiation, transactions, time-outs, and reliability. This article focuses on the notion of (de-) coupling, as it is the source of many distinctions central to the design of distributed applications. Specifically, the article formulates a framework for characterising levels of coupling. The main contributions of the article are:

- A *detailed analysis* of the notion of decoupling in middleware and a formal semantics of dimensions of coupling in terms of Coloured Petri Nets (CPNs) [5].
- A collection of *notational elements* for integration modelling based on the notions of coupling previously identified. These notational elements are given a visual syntax extending that of Message Sequence Charts (MSCs) [6].
- A *classification* of middleware in terms of their support for various forms of (de-)coupling. This classification can be used as an instrument to assist in middleware selection, although requirements outside the scope of this study may play an equally important role in middleware selection (e.g. transaction support, non-repudiation and message filtering capabilities).
- A *prototype* demonstrating the possibility of supporting all styles of coupling in a consistent and uniform way.

The article is structured as follows. Section 2 establishes a nomenclature. Section 3 formalises a set of coupling dimensions while Section 4 shows how these dimensions can be composed, leading to a set of *uni-directional coupling integration patterns* that provide a basis for integration modelling. Section 5 introduces bi-directional interactions and incorporates them into the same conceptual framework. Section 6 presents a framework for comparing middleware solutions based on the uni-directional, and bi-directional patterns. Section 7 introduces *JCoupling*: an open source prototype that combines all of the proposals of this article. Sections 8 and 9 present related work and conclusions respectively.

This article is an extension of our previous analysis of coupling for elementary interactions [7]. It extends [7] to incorporate publish-subscribe techniques into the models of interaction, and by encompassing compound interactions (e.g. request-response). We have introduced remote fault reporting, timeouts, aggregate messaging, and multicast - making the proposals more grounded. This article also introduces a new proof of concept prototype (JCoupling) that implements the theoretical models presented in this article and in [7].

## 2 Background

This section defines key terms related to coupling used in the rest of the paper.

A *message* is a discrete unit of information (containing for example a command, data, request, or an event) that is passed between endpoints. Depending on the technology it may contain header metadata (e.g. message ID/ timestamp) and/or payload data.

An *endpoint* is a communicating entity and is able to perform interactions. It may have the sole capability of sending/receiving messages and defer processing any information to something else, or it may be able to communicate and process.

An *interaction* refers to endpoints exchanging information [8]. The most basic interaction is a uni-directional message exchange (elementary interaction).

A *channel* is an abstraction of a message destination. This abstraction is similar to the notion of “queue” supported by JMS, WebsphereMQ [9], and Microsoft Message Queue (MSMQ) [10]. A common attribute of common queues (channels) offered by WebsphereMQ

and MSMQ is that they are not necessarily private. For instance, these solutions permit many endpoints to invoke a receive request over the same queue (channel) concurrently. In such a case the middleware treats these two endpoints as if they are in fact *competing* for a message [11].<sup>1</sup> Channels can be extended with many functions. Examples include preservation of message sequence [12, 2], authentication, and non-repudiation [11].

A *private channel* is slightly different to a channel in that in this case there is something preventing more than one receiving endpoint from being able to compete for messages on the same channel. A *private queue* (available from WebsphereMQ), is one example where the middleware explicitly doesn't allow certain channels to be shared. Conversely in cases the design or architecture of the middleware won't allow shared channels by design; for example TPC Sockets don't support many applications sharing the same IP-address/port combination.

A *topic* is another form of symbolic destination. Like *channels* many receivers may consume messages off one *topic* – the difference being that all receivers get a copy of the message.

Eugster's survey of Publish-Subscribe [12], introduced three dimensions of decoupling:

- *Thread Decoupling* – (referred to by Eugster as Synchronisation Decoupling) wherein the thread inside an endpoint does not have to wait (block) for another endpoint to be in the 'ready' state before message exchange begins.
- *Time Decoupling* – wherein the sender and receiver of a message do not need to be involved in the interaction at the same time.
- *Space Decoupling* – wherein the messages are directed to a particular symbolic address (channel) and not directly to the address of an endpoint.

The dimensions of decoupling have relevance to a large spectrum of middleware, including MOM, space-based [13], and RPC-based middleware.

### 3 Decoupling Dimensions of an Interaction

This section is based on Eugster's dimensions of coupling. In this section we present conceptual representations and Coloured Petri nets (CPNs) of patterns for coupling distributed applications. At this stage we focus on uni-directional interactions only. Bi-directional interactions (e.g. request-response) are presented in Section 5.

We chose CPNs to formalize the proposed notions of coupling. While we could have used other models of concurrent systems, e.g. Process Algebra [14] or  $\pi$ -calculus [15], we preferred CPN due to its graphical nature, its mature (and freely available) tool support, and the fact that the concept of buffer, which is central in the formalisation, maps directly to the concept of place in Petri nets.

All CPNs have been fully implemented and tested using CPN Tools [16].

#### 3.1 The Thread-coupling Dimension

Thread-decoupling enables "non-blocking communication", for either, or both, the sender and receiver. Non-blocking communication allows the endpoint's thread to interleave processing with communication. In the following paragraphs we introduce some notational elements for various forms of thread decoupling as well as the CPN formalisation.

---

<sup>1</sup> In such circumstances one endpoint will get the message and the other will typically be made to continue waiting/timeout.

**Pattern 1: Blocking Send.**

A message send action can either be blocking or non-blocking. A *blocking send* implies that the sending application must yield its thread of control while the message is being transferred out of the local application. It does not matter if it is passing the message over a wide area network connection or to another local application. If the sender’s thread, at least, blocks until the message has left the local application and its embedded middleware, it is blocking<sup>2</sup>. Figure 1(b) is a CPN of a blocking send. The outer dashed line represents the endpoint while the inner dashed line represents middleware code that is embedded in the endpoint. These do not form part of the CPN language and are used only to indicate architectural concerns.

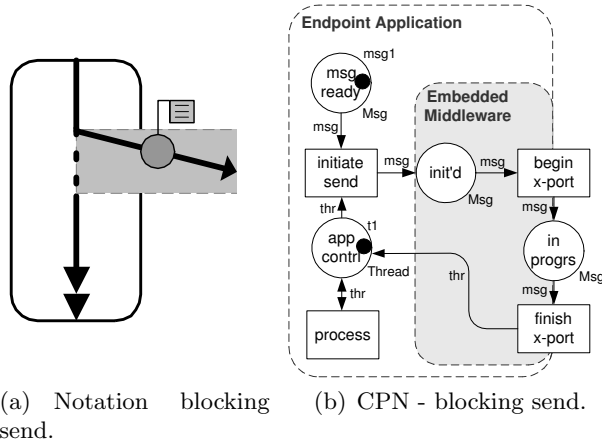

**Fig. 1.** *Blocking send.* After initialising a send action, the transition “*process*” cannot fire until a thread is returned at the end of message transmission.

For readers unfamiliar with CPNs, the next two paragraphs introduce the notation (also see [5]). In Figure 1(b) the circular nodes are called ‘places’ (e.g. “*msg ready*”, “*app contrl*”, and “*in progrs*”), and they represent potential states. The rectangular nodes are called ‘transitions’ (e.g. “*initiate send*”, “*begin x-port*”, and “*process*”), and change a CPN from one state to another. Tokens, e.g. the black dots in the places “*msg ready*” and “*app contrl*”, represent a particular state of the model. Figure 1(b) is in a state where a message is ready to be sent, and the application has control of its own thread. This is the initial state of the CPN, and is referred to as its ‘initial marking’. According to the firing rules of CPNs two transitions (“*initiate send*” and “*process*”) are concurrently enabled for the initial marking. When either of these transitions fire it will consume one token from each of its ‘input places’ and produce one token into each of its output places. A transition is enabled if *every one of its input places contains at least one token*. For example, firing “*initiate send*”, will consume one token from each input place.<sup>3</sup> Consequently the transition “*process*” becomes disabled because “*app contrl*” now contains zero tokens. Transition “*process*” cannot become re-enabled until the transition “*finish x-port*” returns a token to the place “*app contrl*”. “*Finish x-port*” only returns this token once the message has left the sender. In Figure 1(b) the places are type-constrained. For instance the place “*msg ready*” can only hold tokens of type *Msg* – shown as an annotation to its bottom-right side. The annotations shown at the top-right side of the places “*msg ready*” and “*app contrl*” are references to constant values. The values are used to determine the initial marking of Figure 1(b). For instance the annotation “*msg1*” is a constant value of type *Msg*. Its presence puts a token into the place “*msg ready*”. Each arc

<sup>2</sup> If the interaction was bi-directional it would block longer (Section 5).

<sup>3</sup> By contrast, firing “*process*” will remove the token from “*app contrl*” and then place a token back in the input place (because it has a bi-directional arrow).

entering/leaving a place in this CPN is annotated by a variable – typed according to the place the arc connects to. Arcs leaving transitions specify the value of the token to be produced and may use arbitrary ML [17] functions. This feature will be used in Section 3.3.

In Figure 1(b), when a message is ready (represented by a token inside the place “*msg-ready*”) and the application is ready (represented by a token inside the place “*app-contrl*”) the endpoint gives the message to the embedded middleware.<sup>4</sup> The endpoint yields its thread of control to the embedded middleware, getting control back once the message has completely left the embedded middleware. Inside the embedded middleware the transitions “*begin-x-port*”, “*fin-x-port*”, and the place “*in-progress*” are placed over the edge of the endpoint. This denotes that the remote system (receiver endpoint or middleware service) will bind to the sender by sharing these transitions and the place. The assumption is that inside the middleware, at a deeper layer of abstraction, systems communicate in a time-coupled, thread-coupled manner, regardless of the behaviour exposed to the endpoint applications.<sup>5</sup> Therefore this CPN may be “transition bounded” with remote systems.<sup>6</sup>

In a blocking send there is a thread coupling of the sender application (endpoint) with something else – but not necessarily the receiver as we will show in Section 3.2.

**Pattern 2: Non-blocking Send.** A *thread decoupling* is observable at the sender in the case of a *non-blocking send* [12]. A non-blocking send means that message transmission and local computation can be interleaved [18]. Figure 2(a) presents a notation for non-blocking send, based on the MSC notation [6]. Figure 2(b) defines the concept in CPN form. This figure, like that of blocking send (Figure 1) is transition bounded with remote components through the transitions in the embedded middleware of the application. Snir and Otto provide a detailed description of non-blocking send [18].

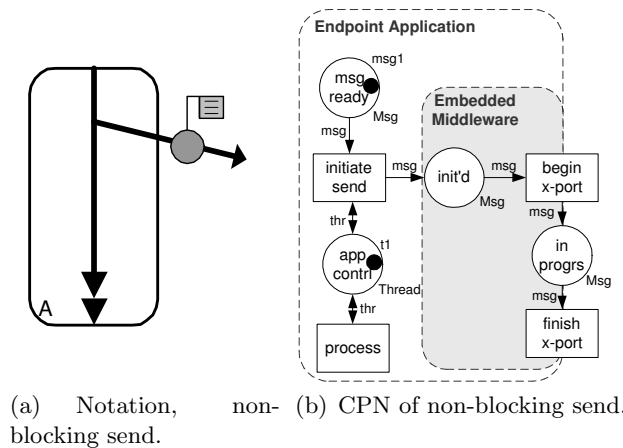

**Fig. 2.** *Non-blocking send.* The transition “*process*” can be interleaved with communication steps because a thread is not yielded to the embedded middleware.

<sup>4</sup> In this series of CPNs we represent tokens as black dots. This is not strictly necessary as the initial markings are shown textually. It is however, a convention we adopt that is intended to assist their readability.

<sup>5</sup> Not all underlying network protocols are time-coupled and thread-coupled (e.g. User Datagram Protocol), however if a messaging technology is going to offer any degree of reliability or data integrity a time-coupled, thread-coupled technique becomes essential. For instance WebLogic JMS (BEA WebLogic [www.bea.com](http://www.bea.com) accessed March 2008), and Email/SMTP (<http://www.ietf.org/rfc/rfc0821.txt> accessed June 2008) both use Transmission Control Protocol (which happens to be thread-coupled and time-coupled); despite this fact they both expose thread/time decoupled APIs.

<sup>6</sup> “Transition bounded”, in this context, means that two distributed components share a transition (action), and must perform it at exactly the same moment.

A non-blocking send is a necessary condition, but not a sufficient condition to achieve total thread decoupling, which is to say that the receive action must also be non-blocking. Rephrased, if both the send and receive are blocking (non-blocking) then a total thread coupling (decoupling) occurs. A partial thread decoupling occurs when the send is blocking and the receive non-blocking, or vice-versa.

The non-blocking send is fairly uncommon for middleware solutions. For instance all RPC-based implementations use blocking send. MOM implementations such as “Websphere MQ” [9] and MSMQ partially support it; but only if the middleware service was deployed onto the local host, the send operation only blocks while the message is passed between applications on the same machine.

**Pattern 3: Blocking Receive.** Like message send, message receipt can either be blocking or non-blocking [2]. The definition of *blocking receive* is that the application must put a thread into a waiting state in order to receive the message (ownership of the thread is usually returned to the endpoint when the message is received). This means that the receiver thread is coupled to either the message sender directly or to some form of queue on a middleware service (depending on whether the middleware queues messages between the sender and receiver, or not). Section 3.2 formalises this notion. Figure 3 presents a notation and model for blocking receive. When the transition “*initiate receive*” of Figure 3(b) is fired, the token sitting in place “*thread*” is consumed, and a token is put into place “*rcv ready*”. Consequently, the transition “*process*” is no longer enabled. Meaning that the model cannot progress until a message arrives (i.e. the receiver is in the blocking state). This may occur before a corresponding sender endpoint sends its message.

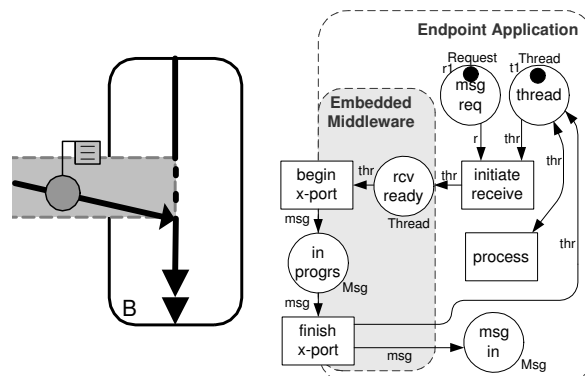

(a) Notation, blocking receive. (b) CPN of blocking receive.

**Fig. 3.** *Blocking receive.* A thread must be yielded to the embedded middleware until the message has arrived.

**Pattern 4: Non-blocking Receive.** The *non-blocking receive* occurs when the application can receive a message, without forcing the current thread to wait. This is illustrated in Figure 4.

A well-known embodiment of non-blocking-receive is the event-based handler described in JMS [4]. Once a handler is registered with the middleware it is called-back when a message arrives. The Message Passing Interface (MPI) provides another embodiment of non-blocking receive that is not event-based [18], wherein the receiver polls for the presence of a new message.

Non-blocking receive, as a communication abstraction, seems less popular than blocking receive. This is probably because blocking receive interactions are simpler to program and debug [11]. One frequently observes statements about the merits of an asynchronous architecture. While such statements are indeed valid, they usually refer to the merits of queuing

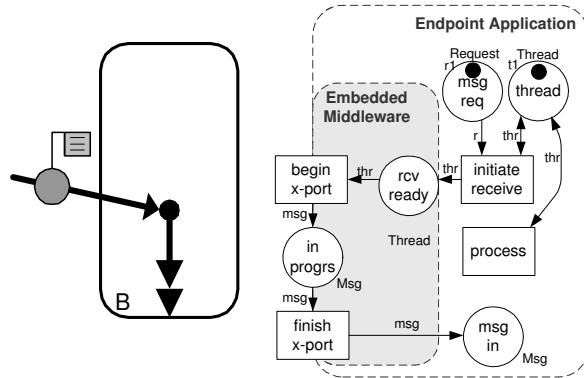

(a) Notation, non- (b) CPN of non-blocking receive.

**Fig. 4.** *Non-blocking receive.* A thread need not be yielded to the middleware in order to receive.

messages between the sender and the receiver, and have little to do with the fact that the threads of control are blocked or not. Therefore the threading dimension as presented in this section is orthogonal to the general usage of the word “asynchronous”.

### 3.2 Time

The dimension of time decoupling is crucial to understanding the difference between many peer-to-peer middleware paradigms and server-oriented paradigms (e.g. MPI versus MOM). In any elementary interaction time is either coupled or decoupled.

**Pattern 5: Time-Coupled.** *Time-coupled* interactions, like those typically found in MPI, cannot take place unless both endpoints are concurrently connected. There is no possibility of queuing messages between the two endpoints. In time-coupled arrangements the interaction begins with the message being wholly contained at the sender endpoint. The transition-boundedness of endpoints can guarantee that the moment the sender begins sending the message, the receiver begins receiving. This concept is presented in Figure 5 wherein the endpoint applications are joined directly at the bounding transitions (“*begin x-port*” and “*finish x-port*”). Time-coupled interactions accord with the general usage of the word “synchronous”. Figure 5 does not show the endpoints. The “sends” and “receives” may be blocking or non-blocking. Hence, Figure 5 should be seen in conjunction with the earlier figures.

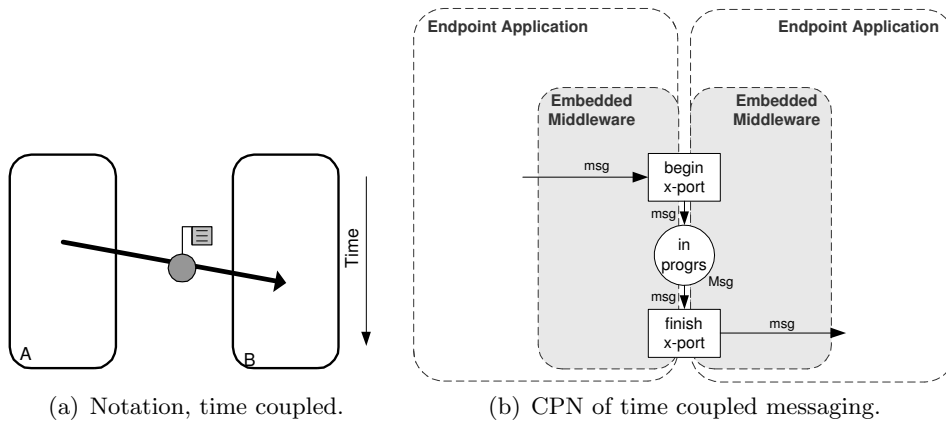

(a) Notation, time coupled. (b) CPN of time coupled messaging.

**Fig. 5.** *Time coupling* is characterised by transition-bounded systems.

**Pattern 6: Time-Decoupled.** *Time-decoupled* interactions allow messages to be exchanged irrespective of whether or not each endpoint is concurrently operational. In this case messages *are queued* between the sender and the receiver. To achieve time decoupling a third endpoint is needed, that both the sender and receiver can access. Time-decoupling is presented in Figure 6. The two endpoints, and the middleware service are again transition-bounded. However now, the middleware service is able to buffer the message, as captured by the place “*buffr’d*”.

The place “*buffr’d*” is filled with a token when the sender has finished sending a message, and the receiver has not started receiving that message. One token in the place “*buffr’d*” represents one message being held on a middleware that sits between the sender endpoint and the receiver endpoint. In Figure 6 the proceeding transition will fire immediately because, in this CPN the presence of a token in “*buffr’d*” enables it. Like in WebLogic’s JMS implementation there is (conceptually) no limitation on the number of messages that can be buffered.

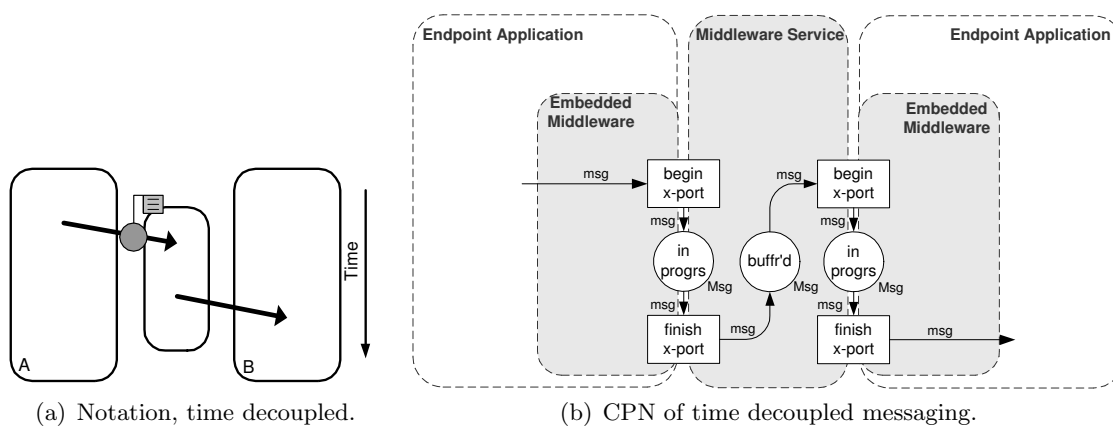

**Fig. 6.** *Time decoupling* is characterised by the presence of an intermediate endpoint.

MOM solutions such as Websphere MQ and MSMQ are typically deployed in a “hub and spoke” arrangement, which is truly time-decoupled. An alternative arrangement is the “peer-to-peer” topology. In such a topology the sender endpoint and middleware service are deployed on the same host. This latter topology may seem time-decoupled, but it is not because interactions can only take place if both hosts are concurrently connected to the network. This may be a problem for endpoints on hosts on unreliable networks, e.g. mobile devices.

### 3.3 Space

Space is the final dimension of decoupling. By “space” we refer a dimension of coupling that takes into account the degree to which sender endpoint can control which instance receives the message. If the sender can totally control which endpoint instance would receive the message we can assume a high degree of space coupling, and vice versa.

**Pattern 7: Space Coupled.** A *space coupled* interaction has the property that only one receiver can possibly receive the message. This behaviour could be driven by, for example, *hard* location data (e.g. an IP-Address/port combination), or more abstract mechanisms incorporated into a middleware (e.g. private queues in IBM Websphere MQ). Figure 7 presents the concept of space coupling. The CPN for space coupling is presented at the end of this section.

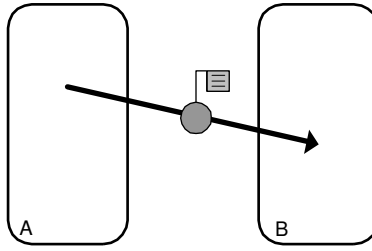

**Fig. 7.** Notation, *space coupled*. The sender directly addresses the receiver.

**Pattern 8: Space Decoupled (Channel) and Pattern 9: Space Decoupled (Topic).** *Space decoupled* interactions on the other hand allow a sender to send a message without requiring explicit knowledge of the receiver’s address. Decoupling in space generally makes architectures more flexible, and extensible.

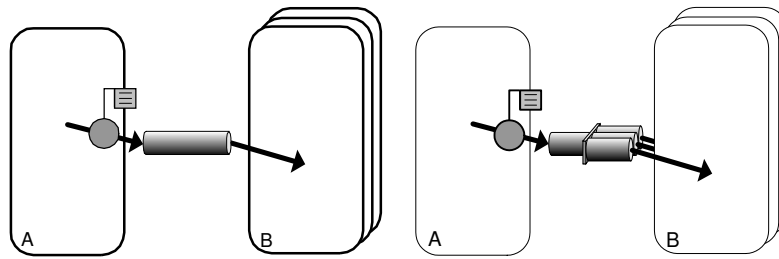

(a) Channel - one receiver gets the message. (b) Topic - all receivers get the message.

**Fig. 8.** Extensions to MSCs representing two forms of space decoupling.

There are two distinct forms of space-decoupling. Space-decoupled architectures permit one sender to interact with *one of many* receivers (over a channel) or *many of many* receivers (over a topic), without uniquely identifying the receiver. Figure 8 introduces extensions to MSCs that present notations for “channel” and “topic” based interactions.

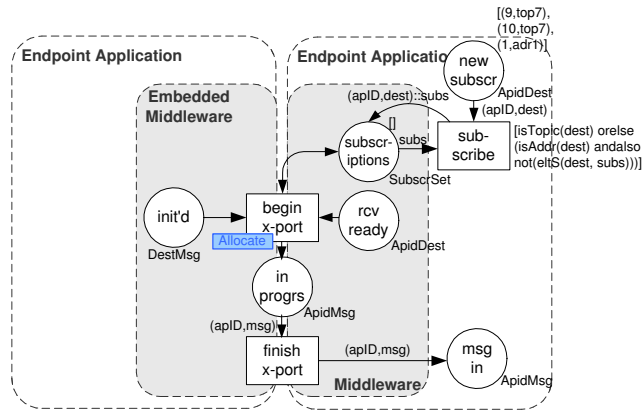

**Fig. 9.** CPN presenting a semantics for the space dimension. The transition “*begin x-port*” has been annotated with a box labelled “*Allocate*”, which means that this transition decomposes to a sub-net (see Figure 10).

In Figure 9, the transition “*begin x-port*” decomposes to the sub-net shown in Figure 10.<sup>7</sup> The sub-net models the behaviour of the three options of the space dimension illustrated by figures 7, 8(a), and 8(b). The places “*new subscr*”, “*subscriptions*” and transition “*subscribe*”

<sup>7</sup> Sub-nets can be used to hide details. Specifically, a transition can be decomposed into a sub-net and by replacing this “substitution transition” by its decomposition one obtains its semantics.



Firing transitions “*begin addr*” or “*begin chan*” require the appropriately typed input tokens, and produce one token referring to the message and its intended application. The difference between the two is that “*begin addr*” can guarantee its token output will always identify the same application for any input address, whereas “*begin chan*” cannot guarantee which application “wins” the message. Firing the transition “*begin topic*” only requires an input token identifying a topic-message, then the application IDs in the subscription set “*subs*” (a set of <application-ID, destination> pairs) that are subscribed to that topic effectively are allocated a copy of the input message. Each subscriber can then obtain, or peel off, its copy of the message using the same technique as for addresses and channels, i.e. by putting a token into the input place “*rcv ready*”. Hence while the interface for each of the three options of space coupling are consistent, the way messages get bound to application-IDs is different.

Thus, direct addressing supports interactions between a sender and *only one* receiver. Channels send the message to *one of many* receivers, and topics to *all of many* receivers. We have chosen not to add a conceptual element that encompasses the notion of a many-to-many interaction. Despite the fact they are observable in real world systems, they seem to be better described as combinations of one-to-one/one-to-many interactions described in this paper; and/or many-to-one interactions [19].

**Patterns M1 & M2 - Multicast and Message Joining.** Multicast involves sending a message to many receivers. This is orthogonal to the space dimension, and in particular, publish-subscribe. Indeed multicast corresponds to a set of interactions to several destinations. It can be achieved by performing several interactions in parallel or in any order. Each of these interactions may have as a destination, an address, an channel, or a topic. Such an approach yields *Pattern M1*.

The converse to multicast is the multiple message join (*Pattern M2*) or aggregate receive. Essentially many messages are received as an aggregated batch. Once again, this is orthogonal to the dimensions of (de-) coupling.

Support for multicast and message join are useful features of a messaging solution. Thus they are strongly related, however they do not cut into the coupling dimensions.

### 3.4 Summary

The coupling integration patterns defined in this section consolidate existing intuitive notions of tightly versus loosely-coupled communication. Having conceptualized these notions, we can now reason about them and about their possible combinations. In particular, we can seek to confirm the orthogonality of these notions. Moreover, the coupling integration patterns can help to delineate fundamental differences between various forms of middleware.

We contend that this set of coupling integration patterns can be used in defining interaction requirements during system analysis and design. Each pattern is sufficiently specific and precise in terms of concept and behaviour.

## 4 Combining Threading, Time, and Space

We contend that the dimensions of decoupling presented in the previous section are orthogonal to each other. Hence, any pattern for thread-coupling can be combined with any pattern for time-coupling, which in turn can be combined with any pattern for space-coupling. Hence,

a quick combinatorial calculation yields twenty four ( $2^2 * 2 * 3 = 24$ ) possibilities for uni-directional coupling. We use the term *coupling integration configuration* to designate a given combination of options across the three dimensions. Figures 17, 18, and 19, in Appendix C, enumerate a merged notation for each combination. The semantics of each coupling integration *configuration* can be precisely defined by a CPN, obtained by combining selected CPNs for each of the three dimensions as explained below.

#### 4.1 CPN Merging.

By combining the CPNs for each of the three dimensions, using CPN Tools, we have verified that the dimensions are indeed orthogonal. In other words, any CPN from each of the dimensions can be combined with any CPN from any other dimension, and the resulting merged CPN preserves the behaviour of its constituent CPNs.

Minor adjustments are required when merging the CPNs. Due to space constraints we will only present the procedure we followed to create two of the twenty four possible merged CPNs. The other twenty two possible CPNs can be created similarly.

Figure 11(b) models a thread-coupled (i.e. synchronisation-coupled), time-coupled, space-coupled combination. Our first step was to start with the blocking send (Figure 1(b)) and blocking receive (Figure 3(b)), and merge these two CPNs together along their similarly labelled nodes “*begin x-port*”, “*in progrs*” and “*finish x-port*”. This merged CPN is time-coupled, and therefore we do not add any intermediary between the blocking send and the blocking receive.

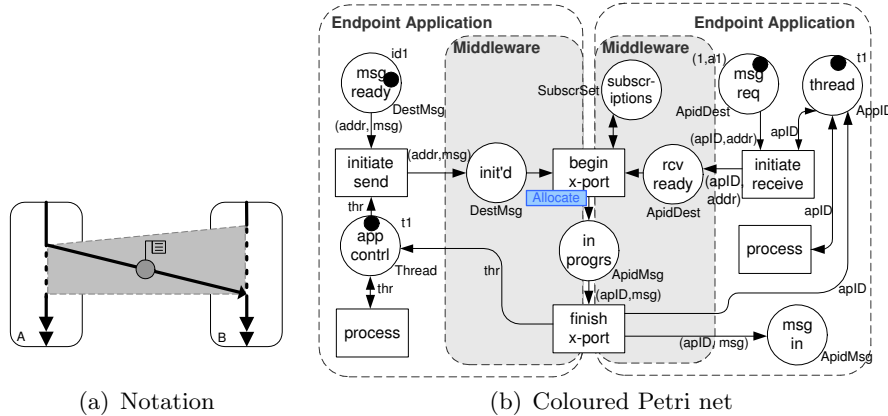
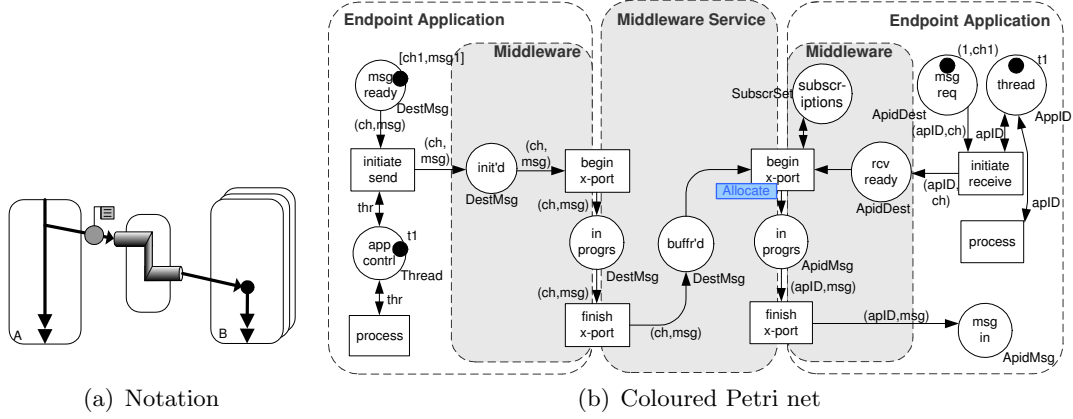

**Fig. 11.** Modelling a thread-coupled, time-coupled, space-coupled interaction.

A second example of a merged CPN is presented in Figure 12(b). It models a thread-decoupled, time-decoupled, space-decoupled (channel) interaction. Being time-decoupled we added a “middleware service” between the sender and receiver, and stitched the boundary nodes (transitions and places) of the sender and receiver to this service.

#### 4.2 Procedure for building a combined CPN

In this section we present a general procedure that builds combined CPNs from the CPNs of the coupling dimension patterns presented in Section 3. The commonly named transitions and places from each dimension (e.g. “*begin x-port*” and “*in progrs*”) are the *stitching* points we use to build these combined CPNs.



**Fig. 12.** Modelling a thread-decoupled, time-decoupled, and space-decoupled interaction.

- Step 1** To the choice of sender - Fig. 1(b) or 2(b) - update the places “*msg ready*” and “*init'd*” from the colour-set *Msg* to the colour-set *DestMsg* (as shown for the space dimension CPN in Fig. 9). This combines *Destination* and *Message* data.
- Step 2** To the choice of receiver - Fig. 3(b) or 4(b) - update the places “*rcv ready*” and “*msg req*” to the colour-set *ApidDest* (as shown for the space dimension CPN). This identifies the receiver application ID (*Apid*) and the Channel/Topic/Address (*Dest*).
- Step 3** Join choice of sender - Fig. 1(b) or 2(b) - to the choice of receiver - Fig. 3(b) or 4(b) - using boundary nodes “*begin xport*”, “*in progrs*”, and “*fin xport*”. Include (exclude) the Middleware service in Fig. 6(b) if the combined model is (not) time-decoupled.
- Step 4** Bind the sub-net “*Allocate*” (Fig. 10) to the transition “*begin x-port*”. If there are two so labelled transitions (as is the case in time-decoupled models) only bind the sub-net “*Allocate*” to the receiver’s instance of transition “*begin x-port*” as shown in Fig. 12(b). For future reference we’ll call this transition **begin-x-port(Allocate)**.
- Step 5** Update the places “*in progrs*” and “*msg in*” leading away from the transition **begin-x-port(Allocate)**, from the colour-set *Msg* to the colour-set *ApidMsg*. This identifies the intended receiver application ID (*Apid*) and the *Message*.
- Step 6** If the merged CPN is time-decoupled update the places (“*in progrs*” and “*buffr'd*”) leading towards the transition **begin-x-port(Allocate)** from colour-set *Msg* to colour-set *DestMsg* as shown in Fig. 12(b).

## 5 Bi-directional Interactions

Bi-directional interactions generally involve a requestor, and a respondent. As a general observation, middleware based on an RPC paradigm support bi-directional interactions, while Message-Oriented Middleware are oriented towards uni-directional messaging. For instance RPC-based middleware (e.g. CORBA [3]) supports “request-response” interactions, whereas MOM based middleware (e.g. Microsoft Message Queueing – MSMQ), do not natively support request-response interactions.

There are exceptions to this general observation, such as the JMS API. JMS provides partial support for request-response using its *QueueRequestor* and *TopicRequestor* classes, but these only serve to mask the two interactions occurring over the native JMS provider from the requestor’s perspective. Further, these classes do not report remote exceptions and

the TopicRequestor returns only the first response and ignores the responses of all other subscribers.

The analysis of (de-) coupling has thus far only accounted for uni-directional interactions. Bi-directional interactions, the exchanging of data in two directions, occurs within the scope of a single interaction for RPC style middleware. We challenge the notion that only thread-coupled systems allow bi-directional messaging within an interaction.

Bi-directional messaging, adds additional possibilities – for instance delivery receipt, and the reporting of receiver-side faults. A delivery receipt (i.e. system acknowledgement) is an event returned to the requestor, that its message has been successfully received. A delivery receipt (as distinguished from a response) does not imply that the targeted endpoint has processed the message – just that it has received it. Finally a receiver side fault being propagated back to the requestor indicates that an error occurred during the processing of the request message.

Likewise timeouts are also a relevant aspect to consider when modelling interactions. So far they have not been presented even though we have modelled application-level faults. Appendix D presents a timed-CPN of *Blocking-send*, *Blocking-recv* showing how timeouts fit into that particular pattern combination.<sup>9</sup> Appendix D also summarises the results of simulations conducted on these timed CPNs.

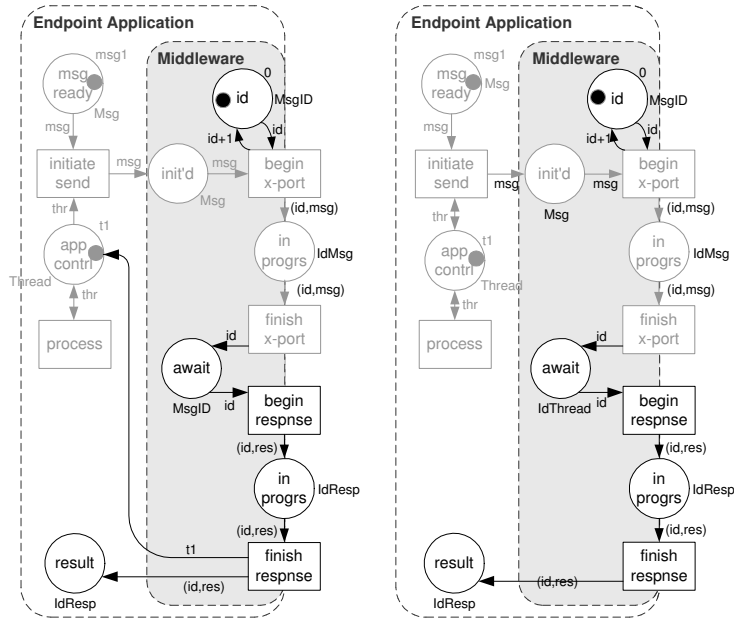

(a) CPN of blocking send with response, or delivery receipt. (b) CPN of non-blocking send with response, or delivery receipt.

**Fig. 13.** Extended CPNs dealing with thread-coupling in bi-directional interactions from the requestor side. The changes made to the related CPNs from Section 3 are black, while the unchanged elements are grey.

The CPN models from Section 3 covering threading and time were extended to *optionally* support request-response interactions, fault notification, and/or delivery receipt. These extended CPNs (see figures 13 and 14) preserve the orthogonality of time, space, and threading. In Figure 13 the structure of the boundary nodes (“*begin x-port*”, “*in progrs*”, “*finish x-port*”, “*begin response*”, and “*finish response*”) in either CPN is identical. The major difference being

<sup>9</sup> Note also that the prototype mentioned in Section 7 addresses timeouts and networking faults.

that Figure 13(a) waits for the result, whereas Figure 13(b) continues processing immediately. The application in Figure 13(b) can rendezvous with the result when it is ready.

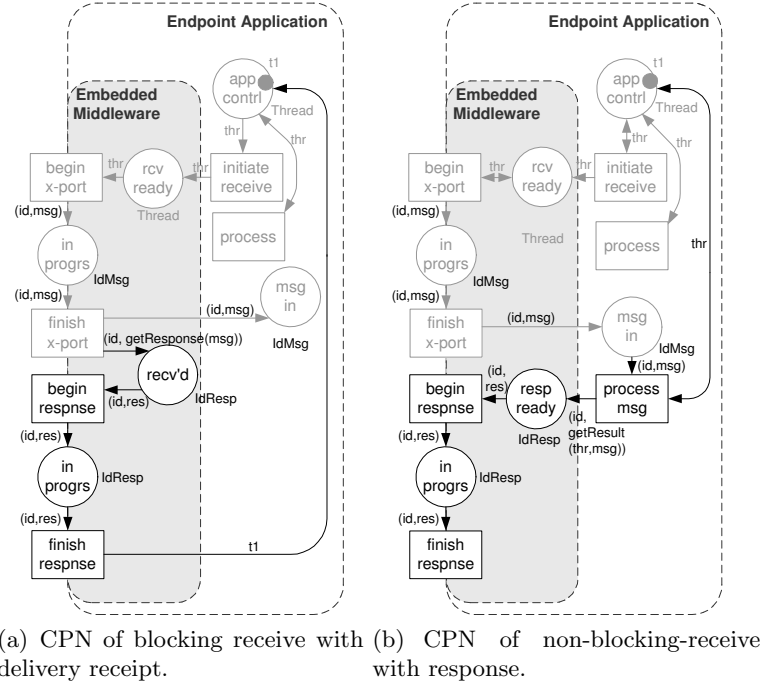

**Fig. 14.** Extended CPNs dealing with thread-coupling in bi-directional interactions from the respondent side. The changes made to the related CPNs from Section 3 are black, while the unchanged elements are grey.

One can observe that the alternative CPNs of Figure 14 do preserve their blocking and non-blocking behaviour respectively. The CPN for blocking receive (Figure 14(a)) includes the return of a delivery receipt, whereas non-blocking-receive (Figure 14(b)), includes the return of a response/fault. A delivery receipt is not intrinsic to blocking receive, just as responses and fault notification are not intrinsic to non-blocking-receive. They are presented in these CPNs as alternatives, a choice more inspired by expediency.

We have seen that it is necessary to extend the CPNs for thread-coupling in order to cover responses. It is also necessary to extend the CPNs for the dimension of time. Figure 15 (request, optional response, time-decoupled) shows that the response is generated by the intermediate point of the interaction. This means that for time-decoupled interactions the semantics that two systems can interact without being active concurrently is preserved. The place “*resp ready*” stores and returns a signal to the requestor indicating the message has been buffered, and is ready for the receiver to retrieve. If the case arises that the requestor still wishes to retrieve a response from the respondent in a time-decoupled manner, the CPN of Figure 15 allows for this by providing an optional response polling service. This is started at the place “*polling*” and continues through transition “*bgn td respnse*”. We do not include the extended CPN for “time-coupled” interactions, because it is a trivial extension of Figure 5(b).

We have concluded that in fact delivery receipts (system acknowledgements), responses, and faults can be added to the semantics of blocking/non-blocking, time-coupled/time-decoupled topologies without interfering with their original semantics, as defined in Section 3. Therefore it would be useful, when comparing middleware solutions in terms of their coupling, to also take into account their relative support for alternative patterns of response. Based on

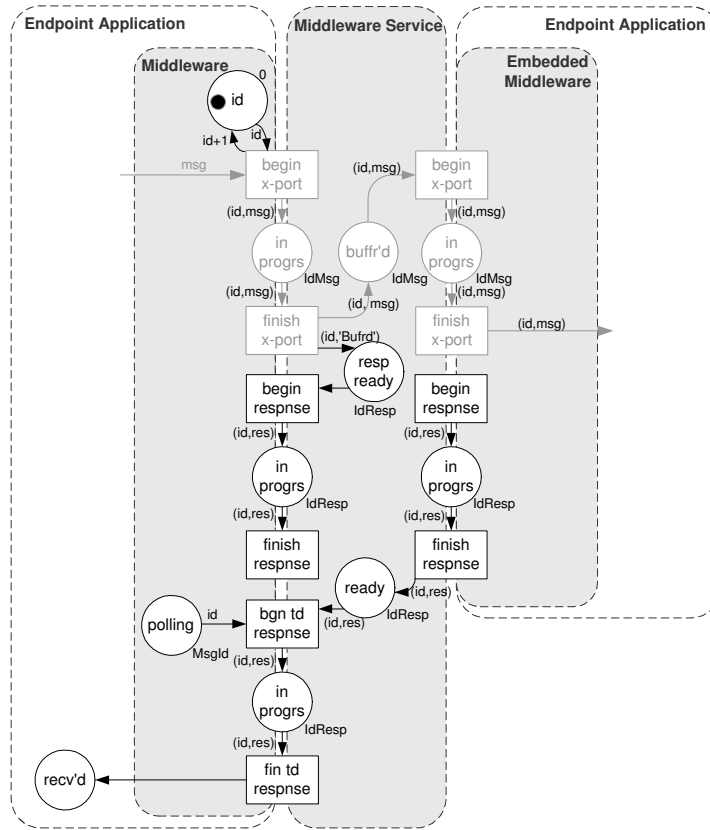

Fig. 15. Time decoupling CPN, extended to cover request-response interactions.

our survey of middleware solutions/standards, and theoretical modelling, we have arrived at these patterns of request-response:

- Pattern R1: Preprocess acknowledgement** a signal, provided by the middleware, is returned to the requestor indicating the successful receipt of the message.
- Pattern R2: Postprocess acknowledgement** a signal, provided by the middleware, gets returned to the requestor indicating that the message was successfully processed.
- Pattern R3: Postprocess response** a response, containing information provided by the respondent, gets returned to the requestor.
- Pattern R4: Postprocess fault** an exception/fault occurs in the respondent while processing the message, and information about this gets propagated back to the requestor.
- Pattern R5: Receive response: blocking** the requestor blocks for the response.
- Pattern R6: Receive response: non-blocking** the requestor thread uses a non blocking technique to receive the response.

The options for responding to a message do not interfere with the semantics of coupling and decoupling. For example, time-decoupling enables, but does not force “fire and forget” interactions. Likewise, a blocking-send does not imply a response, and a non-blocking send does not imply the lack of one.

## 6 Comparison of Middleware Solutions and Standards

The concepts presented in this paper, are supported by a range of middleware solutions and standards, but to varying degrees and in different combinations.

Therefore, in this section we propose that these concepts can be used to evaluate various middleware solutions and standards. Such an evaluation may be of assistance to architects deciding between technologies based on the requirements with respect to levels of coupling or decoupling between distributed systems. To illustrate this proposition, we have evaluated the following: Java-spaces<sup>10</sup>, Axis [20], CORBA [3], JMS<sup>11</sup>, Websphere MQ<sup>12</sup>, MSMQ [10], and MPI<sup>13</sup>.

First of all it is important to establish that with any of these standards and solutions, it is possible to implement all of the concepts. The question we are addressing is the relative level of effort required to achieve it. The results of this evaluation are presented in Table 1 in Appendix A. Solutions that directly support a pattern are given a plus ('+'). Those able to support a pattern using minor work-arounds are given a plus minus ('+/-'), and those requiring greater effort are assigned a minus ('-'). A detailed rationale behind these assessments is provided in Appendix B.

In Table 1 Patterns C1 to C9 in the table represent the coupling integration patterns presented in Sections 3.1, 3.2, and 3.3. Patterns M1 and M2 represent the two patterns related to multicast and message joining presented in Section 3.3. Patterns R1 to R6 represent patterns of request-response as presented in Section 5.

**Scenario - Mobile Devices and a BPM System.** Consider a hospital that needs to integrate a Business Process Management (BPM) system and a proximity sensor system to send requests to medical staff based on their skills and location. Each medical staff is given a mobile device that relays location information to a central system. The BPM system uses this information to allocate work items to perform patient care services in an efficient, timely manner.

The challenge is to design an integration model accounting for the varying levels/types of connectivity between distributed systems, and mobile resources. Clearly the mobile devices will not always be connected to the central system (due to varying levels of signal availability), and therefore the use of non-blocking send is advisable. Hence messages to and from mobile devices could be stored until the signal is restored. New mobile devices might need to be added to the system and device swapping may occur – which should not break the integration. Therefore space decoupling is required, but we do not want to notify many instances of the same resource with the same work request, thus ruling out publish-subscribe. Finally, it is likely that the mobile devices have intermittent connectivity and therefore time decoupling between mobile devices and the central system is necessary.

Based on these requirements it is clear that one should use a combination of Pattern 2 (Non-blocking-send), Pattern 3/4 (Non-blocking-receive/Blocking-receive), and Pattern 6 (Time-decoupled). Combined this could amount to either configuration 'C14' (Non-blocking-send, *Blocking-recv*, Time-decoupled, Space-decoupled-channel) or configuration 'C16' (Non-blocking-send, *Non-blocking-recv*, Time-decoupled, Space-decoupled-channel) from Appendix C.

The table (Table 1) shows that only JMS, Websphere MQ, and MSMQ could support such a combination of requirements. Furthermore the table suggests a potential sticking point for each of these solutions as they all only partially support Pattern 2 (Non-blocking-send).

<sup>10</sup> Java Spaces <http://java.sun.com/developer/products/jini/index.jsp>, accessed March 2008.

<sup>11</sup> J2EE-SDK V. 1.4, <http://java.sun.com/products/jms/>, accessed March 2008.

<sup>12</sup> Websphere MQ V 5.1, [9].

<sup>13</sup> MPI Core: V. 2, [18].

## 7 Prototype

In the spirit of validating the proposal, we designed an API on top of the Java language, namely JCoupling. JCoupling was introduced in [19] as a means of enabling correlation of messages to instances of a business process through the use of properties, channels and filters. In this paper, we do not consider the issue of message correlation and filtering, focusing instead on the coupling integration patterns and the request-response patterns. JCoupling combines the ideas presented in this paper with those presented in [7].

JCoupling is not a middleware per se: It does not provide application services traditionally associated with middleware such as reliable delivery (i.e. retries), transactions, security, etc. Its purpose is merely to illustrate how the proposed concepts can be used to support different types of communication through a unified API. The source code of the prototype is available from [www.sourceforge.net/projects/jcoupling](http://www.sourceforge.net/projects/jcoupling).

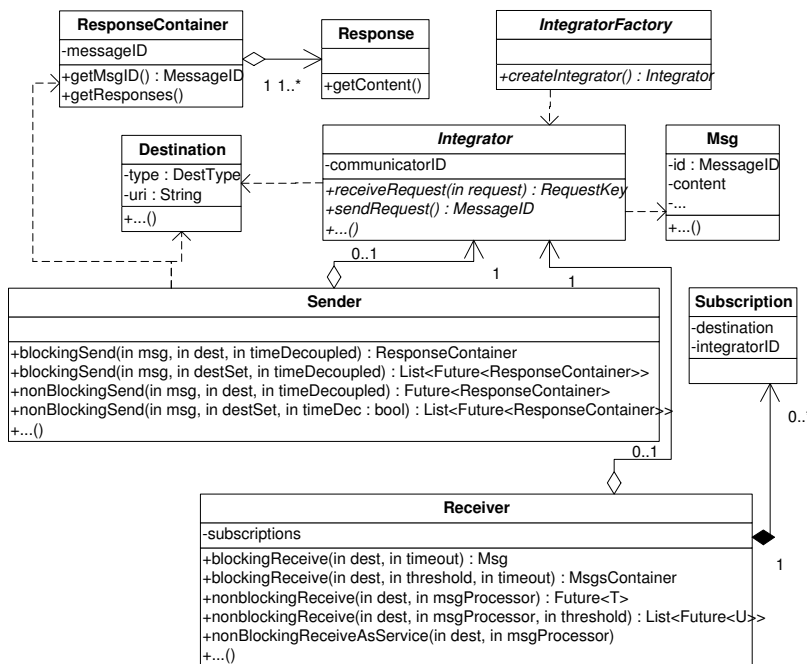

Fig. 16. UML diagram showing key classes of the JCoupling API.

Figure 16 presents a summary of the JCoupling API. It can be seen from this figure that the abstract class `Integrator` is central to the JCoupling API. Concrete implementations of `Integrator` perform the transport responsibilities, required by any `Sender` and `Receiver`. For instance, a possible implementation of `Integrator` could enable interactions over TCP sockets. The `JCouplingFactory` interface provides a dynamic means of creating instances of alternative implementations of the `Integrator` class. For instance an implementation of this interface could create either a JMS, TCP, or SOAP/HTTP `Integrator` implementation based on the contents of a text-based configuration file.

As shown in Figure 16, the `Integrator` interface has two primary methods:

- `receiveRequest()` immediately returns a `RequestKey` identifying the interaction request, and then places the request onto the JCoupling server (which is not shown). When a message is ready, on the JCoupling server, a call-back is made by the server onto the

requesting `Integrator` correlating the original request using the same key. This notifies the `Receiver` to retrieve the message off the server. The blocking or non-blocking interaction styles are implemented within the `Receiver`, which is akin to the way they were modelled in the CPNs of previous sections.

- `sendRequest()` operates in a similar manner, except that a `MessageID` is used instead of a request key, and that the client is a `Sender`.

Non blocking methods on both the `Sender` and the `Receiver` immediately return `java.util.concurrent.Future` objects. An object of type `Future` is essentially a handle to obtain a desired object once it is ready. The methods of `Sender` and `Receiver` that return lists are concerned with multicast and aggregate message receipt.

**Example 1: Hello World.** The following listings demonstrate the implementation of an interaction using the Blocking-send, Blocking-recv, Time-decoupled, and Space-decoupled (Channel) patterns, as presented in Section 3. Such a coupling configuration mimics the common behaviour observable in most Message Oriented Middleware.

**Listing. 1.** Performs a time-decoupled, space-decoupled, blocking-send.

```
1   ...
2   IntegratorFactory factory = new LocalIntegratorFactory();
3   try{
4       Integrator integrator = factory.createIntegrator();
5       Sender sender = new Sender(integrator);
6       Channel channel = (Channel) integrator.lookup(CHANNEL_URI);
7
8       Message message = new Message();
9       message.setContent("Hello World");
10
11      sender.blockingSend(message, channel, TimeCoupling.decoupled);
12  } catch (JCouplingException e) { ... }
```

In Listing 1, line 2 creates a factory capable of instantiating `Integrator` objects, which basically allows client code to abstract away from the underlying transport protocol. Lines 5 - 6 create the sender and obtain a reference to the channel. Line 11 sends the message over this channel in a time-decoupled manner. Line 12 is needed because lines 4 and 11 can throw either a `TransportException`, `NotFoundException`, or a `PermissionException` (all sub-types of `JCouplingException`).

**Listing. 2.** Performs a space-decoupled, blocking receive.

```
1   ...
2   try{
3       Integrator integrator = factory.createIntegrator();
4       Receiver receiver = new Receiver(integrator);
5       Channel channel = (Channel) integrator.lookup(CHANNEL_URI);
6
7       Message message = receiver.blockingReceive(channel, Receiver.NEVER_TIMEOUT);
8
9       // At this point, the message has been received
10      ...
11  }
12  catch (JCouplingException e) { ... }
13  catch (TimeoutException e) { ... }
```

In Listing 2, lines 3 - 5 create the receiver, and obtain a reference to the channel. Line 7 performs the receive - returning a `Message` object.

**Example 2: “Scatter-gather”.** A “scatter-gather” interaction is akin to an RPC Broadcast: given a collection of endpoints, a request is sent to each of these endpoints, and a response is later gathered from each of them. For demonstration purposes we will portray a purchase order scenario. When a purchase order is received by *Hardware-R-Us* an inventory check reveals that certain line items are understocked. So *Hardware-R-Us* performs a scatter-gather request on three wholesalers for a quote, with the best quote being pursued.

Hohpe and Woolf [11] propose an implementation of the *scatter gather* pattern using JMS. The endpoint playing the role of *Hardware-R-Us* sends a request onto a JMS topic, and each wholesaler receives the request, creates a quote, parses the request for a return address, and posts the quote on the queue. The “*Hardware-R-Us*” endpoint receives each quote, one by one, keeping the best.

To implement the same scatter-gather using JCOupling requires less coding. *Hardware-R-Us* publishes a non-blocking-send, as shown in Listing 3.

**Listing. 3.** Publishes a search request to all libraries, and filters for the best responses.

```
2    try {
3        IntegratorFactory factory = new LocalIntegratorFactory();
4        Integrator integrator = factory.createIntegrator();
5        Sender sender = new Sender(integrator);
6        Topic topic = (Topic) integrator.lookup(TOPIC_URI);
7
8        Message message = new Message();
9        message.setContent(BOOK_REQUEST);
10
11        Future<ResponseContainer> futureResponses =
12            sender.nonBlockingSend(message, topic, TimeCoupling.coupled);
13
14        ...// do something else while responses are coming back
15
16        ResponseContainer responseContainer = futureResponses.get();
17        List<Response> subscriberResponses = responseContainer.getResponse();
18        List<Response> goodResponses = filterResponses(subscriberResponses);
19        ...
20    } catch (JCOuplingException e) { ... }
21    catch (ExecutionException e) { ... }
22    catch (InterruptedException e) { ... }
```

The wholesaler endpoints don’t need to explicitly receive messages, inspect return addresses, and send replies, they only need to implement an interface and add it to a **Receiver** object (Listings 4 and 5).

**Listing. 4.** The message processor interface.

```
1    public interface MessageProcessor<V>{
2        public V processMessage(Message message) throws Exception;
3        public <U extends Serializable>U getResponse();
4    }
```

Implementations of **MessageProcessor** should provide the application logic needed to process the message, and to format a response. Method **processMessage** gets called first, then **getResponse**. The result of invoking **getResponse** gets returned to the sender.

**Listing. 5.** Creates a search receive/response server for a wholesaler.

```
1    try {
2        IntegratorFactory factory = new LocalIntegratorFactory();
3        Integrator integrator = factory.createIntegrator();
```

```

4     Receiver receiver = new Receiver(integrator);
5     Topic topic = (Topic) integrator.lookup(TOPIC_URI);
6     receiver.subscribe(topic, TOPIC_PASSWORD);
7
8     QuoteRequestProcessor quoteRequestProcessor = new QuoteRequestProcessor();
9     receiver.nonBlockingReceiveAsService(topic, quoteRequestProcessor);
10  } catch (JCouplingException e) { ... }

```

In Listing 5, lines 4 - 6 create the receiver, obtain the topic reference, and subscribe the receiver to the topic. Lines 8 - 9 instantiate an instance of the `MessageProcessor` interface and register it with the receiver. When a message arrives, the method `processMessage` of `QuoteRequestProcessor` will be invoked (similar to `onMessage` in JMS).

## 8 Related Work

Cypher and Leu [2] provided a formal semantics of blocking/non-blocking send/receive which is strongly related to our work. Their primitives were defined in a formal manner and related to the MPI [18]. This work does not consider space decoupling. Our research differs by combining thread-decoupling with the principles of time and space-decoupling (originating from Linda [13]). Furthermore, our work unified these dimensions to define coupling integration patterns that can be used as a basis for middleware comparison.

Charron-Bost, Mattern, and Tel [21] provide a formalisation of the notions of synchronous, asynchronous, and causally ordered communication. This study introduces a notion of generalisation among these forms of communication according to sequences of messages at the global perspective and cyclic dependencies between them. They propose an increasing gradation of strictness starting with asynchronous computation (akin to all forms of time-decoupled communication), through FIFO computations (akin to message sequence preservation), through causally ordered computations, and finally to the most strict form - synchronous computations (akin to thread-coupled, time-coupled communication). Their formalisation of “asynchronous” is akin to our notion of thread-decoupling; nevertheless they do not distinguish between time-decoupling and thread-decoupling as alternative forms of asynchronous communication. This highlights the fact that their work focusses on formal classifications of distributed message sequences, while our is more architectural in nature. Their work does not address concepts such as space-decoupling, and only mentions request-response very briefly.

Thompson [22] described a technique for selecting middleware based on its communication characteristics. Primary criteria include blocking versus non-blocking transfer. In this work several categories of middleware are distinguished, including conversational, request-reply, messaging, and publish-subscribe. The work, while insightful and relevant, does not attempt to provide a precise definition of the identified categories and fails to recognise subtle differences with respect to non-blocking communication. Our work, on the other hand contains precise definitions for blocking and non-blocking communication and it addresses the dimensions of time and space.

Schantz and Schmidt [23] described four classes of middleware: *Host infrastructure middleware* (e.g. sockets), *Distribution middleware* (e.g. CORBA [3], and RMI [24]), *Common Middleware Services* (e.g. CORBA and EJB), and *Domain Specific Middleware Services* (e.g.

EDI<sup>14</sup> and SWIFT<sup>15</sup>). This classification provides a compelling high-level view on the space of available middleware. Their classification focusses on architectural concerns and domain-oriented criteria. While this classification does offer important differentiations between alternative forms of middleware it does not highlight these alternatives in terms of the coupling architectures available for each middleware alternative. Consequently our work can be construed to complement theirs.

Tanenbaum and Van Steen [25] described the key principles of distributed systems. Detailed issues were discussed such as (un-)marshalling, platform heterogeneity, and security. The work was grounded in selected middleware implementations including RPC, CORBA, and the World Wide Web. Our work is far more focussed on coupling at the architectural level, and therefore complements the technical issues discussed by Tanenbaum and Van Steen.

Barros et. al. [26] produced a set of service interaction patterns. The paper is oriented towards the design and implementation of conversational Web services using process definition languages such as the Business Execution Language for Web Services (BPEL4WS). However, these service interaction patterns do not deal with any notion of space/ time/ or thread decoupling. Request-response interactions are briefly discussed but not incorporated into the other interaction patterns which overall tend to be composed from many atomic interactions and make use of state to arrive at more complex interaction patterns. The ideas are relevant but are highly distinct from our work.

## 9 Conclusion

This article has presented a set of formally defined notational elements to capture architectural requirements with respect to coupling. The proposed notational elements are derived from an analysis of middleware in terms of three orthogonal dimensions: (1) threading, (2) time and (3) space. The patterns proposed in this work identify subtle differences between time-decoupling and thread-decoupling. Either time-decoupling or thread-decoupling, alone, can in fact provide what is commonly regarded as asynchronous behaviour, somewhat overloading the term's meaning; and yet in some middleware examples they are both present (e.g. MPI, JMS) – underlining their distinctness.

In this paper, we have argued that the terms ‘synchronous’ and ‘asynchronous’ are too imprecise to constitute a foundation for defining models of integration. This inspired us to define a set of coupling integration patterns that conceptualize the notions of synchronous and asynchronous communication, among others, in an unambiguous manner. We also linked multicast/join patterns, and six request-response patterns into the core concepts. This set of patterns unifies and organises existing knowledge in the domain of integration coupling. We have also presented an embodiment of the proposed concepts in the form of an API, namely JCoupling.

Our key motivation for this paper was to address the lack of an overarching framework that can unambiguously express architectural requirements with respect to (de-)coupling. We believe that the proposed coupling patterns introduced throughout this article offer a sufficient solution to this goal, and that the CPN models underpinning these patterns offer an unambiguous expression of their semantics.

---

<sup>14</sup> EDI: Electronic Data Interchange is a set of standards defining electronic document structure for business to business communication. There are two standards sets for EDI, one adopted by the ISO <http://www.unece.org/trade/untdid/welcome.htm>, and one adopted by ANSI <http://www.x12.org/> (accessed Jan 2007).

<sup>15</sup> SWIFT: Society for Worldwide Interbank Financial Telecommunication. SWIFT provide a value added network enabling messages concerning transactions to be exchanged between banks of the world (<http://www.swift.com> accessed Jan 2007).

In collaboration with Gecko (<http://www.gecko.de/> accessed May 2008), we are currently working on building a commercial form of the JCoupling API. We plan to add a middleware aggregation layer to the implementation, allowing JCoupling to pass interaction requests over alternative forms of *outward facing* middleware, including JMS and WSDL-based implementations. A meta-data layer will allow us to capture the semantics, programatically, of the *outward facing* middleware quite concisely, so that applications can “reason” about the semantics of different forms of middleware. As part of this work we intend to conduct load testing. We also reported in [19], some extensions to the JCoupling API to deal with message filters, and we have shown how this enables the implementation of sophisticated forms of message correlation in the context of business process management systems. We are currently extending this work to integrate it into a workflow engine, namely YAWL [27].

**Disclaimer** The assessments we made of middleware products and standards with respect to the coupling integration patterns are based on the tool or standard’s documentation and, in some cases, experimentation. They are true and correct to the best of our knowledge.

**Acknowledgement** This work was partly funded by an Australian Research Council Discovery Grant “Expressiveness Comparison and Interchange Facilitation between Business Process Execution Languages”.

## References

1. Beugnard A, Fiege L, Filman R, Jul E, Sadou S. Communication Abstractions for Distributed Systems. *ECOOP 2003 Workshop Reader*. Springer-Verlag, Berlin, volume 3013, 17 – 29.
2. Cypher R, Leu E. The Semantics of Blocking and Nonblocking Send and Receive Primitives. Siegel H, ed., *Proceedings of 8th International parallel processing symposium (IPPS)*. 729–735. URL [citeseer.ist.psu.edu/cypher94semantics.html](http://citeseer.ist.psu.edu/cypher94semantics.html).
3. Group O M. *Common Object Request Broker Architecture: Core Specification*, 3.0.3 edition, 2004. <http://www.omg.org/docs/formal/04-03-01.pdf> accessed Sep 2007.
4. Hapner M, Burrige R, Sharma R, Fialli J, Haase K. *Java Messaging Service API Tutorial and Reference*. Addison-Wesley, 2002.
5. Jensen K. *Coloured Petri Nets. Basic Concepts, Analysis Methods and Practical Use. Volume 1*. EATCS monographs on Theoretical Computer Science. Springer-Verlag, Berlin, 1997.
6. Rudolph E, Grabowski J, Graubmann P. Tutorial on Message Sequence Charts. *Computer Networks and ISDN Systems* , 1996; **28**(12): 1629–1641.
7. Aldred L, Aalst W, Dumas M, Hofstede A. On the Notion of Coupling in Communication Middleware. *Proceedings of the 7th International Symposium on Distributed Objects and Applications (DOA)*. Springer Verlag, 1015 – 1033.
8. Quartel D, Pires L F, van Sinderen M, Franken H, Vissers C. On the Role of Basic Design Concepts in Behaviour Structuring. *Computer Networks and ISDN Systems* , 1997; **29**(4): 413 – 436.
9. Websphere MQ family. <http://www-306.ibm.com/software/integration/wmq/> accessed Sept 2007.
10. Microsoft Message Queuing. <http://www.microsoft.com/windowsserver2003/technologies/msmq/default.aspx> accessed Sept 2007.
11. Hohpe G, Woolf B. *Enterprise Integration Patterns: Designing, Building, and Deploying Messaging Solutions*. Addison-Wesley, Boston, MA, USA, 2003.
12. Eugster P, Felber P, Guerraoui R, Kermarrec A. The Many Faces of Publish/Subscribe. *ACM Computing Surveys* , 2003; **35**(2): 114–131.
13. Gelernter D. Generative communication in Linda. *ACM Trans. Program. Lang. Syst.* , 1985; **7**(1): 80–112. doi: <http://doi.acm.org/10.1145/2363.2433>.
14. Hoare C. *Communicating Sequential Processes*. Prentice-Hall, Englewood Cliffs, 1985.
15. Milner R. *Communicating and Mobile Systems: The Pi-Calculus*. Cambridge University Press, Cambridge, UK, 1999.
16. CPN Tools homepage. <http://wiki.daimi.au.dk/cpntools/> accessed Sept 2007.
17. Milner R, Tofte M, Harper R, MacQueen D. *The Definition of Standard ML - Revised*. MIT Press, Cambridge, USA, 1997.
18. Snir M, Otto S, S Huss-Lederman D W, Dongarra J. *MPI-The Complete Reference: The MPI Core*. MIT Press, second edition, 1998.

19. Aldred L, Aalst W, Dumas M, Hofstede A. Communication Abstractions for Distributed Business Processes. *Proceedings of the 19th International Conference on Advanced Information Systems Engineering*. Springer Verlag, volume 4495 of *Lecture Notes in Computer Science*, 409–423.
20. Apache Axis homepage. <http://ws.apache.org/axis/> accessed Sept 2007.
21. Charron-Bost B, Mattern F, Tel G. Synchronous, asynchronous, and causally ordered communication. *Distributed Computing*, 1996; **9**(4): 173–191.
22. Thompson J. Toolbox: Avoiding a Middleware Muddle. *IEEE Software*, 1997; **14**(6): 92–98.
23. Schantz R, Schmidt D. *Encyclopedia of Software Engineering*, Wiley & Sons, New York, USA, chapter Middleware for Distributed Systems: Evolving the Common Structure for Network-centric Applications, 2002; .
24. Microsystems S. Java Remote Method Invocation Specification. <http://java.sun.com/j2se/1.5.0/docs/guide/rmi/spec/rmiTOC.html> accessed Sept 2007.
25. Tanenbaum A, M van Steen. *Distributed Systems: Principles and Paradigms*. Prentice Hall PTR, Upper Saddle River, NJ, USA, 2001.
26. Barros A, Dumas M, Hofstede A. Service Interaction Patterns. *Proceedings of the 3rd International Conference on Business Process Management (BPM)*. Springer Verlag, 302–318.
27. YAWL Home Page. <http://www.yawlfoundation.com> accessed June 2008.

## A Comparison Solutions and Standards

Dimension	Option	#	Java Spaces	Axis	CORBA	JMS	Websphere MQ	MSMQ	MPI
Threading	Blocking Send	1	+	+	+	+	+	+	+
	Non Blocking Send	2	-	-	-	+/-	+/-	+/-	+
	Blocking Receive	3	+	-	-	+	+	+	+
	Non Blocking Receive	4	+	+	+	+	+	+	+
Time	Time Coupled	5	-	+	+	-	-	-	+
	Time Decoupled	6	+	+/-	+	+	+	+	-
Space	Space Coupled	7	-	+	+	-	+	-	+
	Space Decoupled - Channel	8	+	-	+	+	+	+	-
	Space Decoupled - Topic	9	+/-	-	+/-	+	+	+/-	+/-
<b>Multicast</b>									
Multicast/Scatter		M1	-	-	-	-	+	+	+
JoinMsgs/Gather		M2	-	-	-	-	-	-	+
<b>Request-Response</b>									
PreprocessAck		R1	-	-	-	+	+	-	+
PostProcessAck		R2	-	+	+	+/-	+/-	-	-
PostProcessResp		R3	-	+	+	+/-	+/-	-	-
PostProcessFault		R4	-	+	+	-	-	-	-
Blocking Receive Ack		R5	-	+	+	+	+	-	-
Non Blocking Receive Ack		R6	-	-	+	-	-	-	-

**Table 1.** Evaluation of selected middleware solutions and standards.

## B Rationale behind the evaluation of Standards and Tools against the Patterns

Table 1 presented an evaluation of middleware standards and tools, in terms of their ability to directly support or partially support the coupling capabilities presented in this article. Solutions that directly support a pattern were given a plus ('+'). Those able to support a pattern using more than a little effort were given a plus minus ('+/-'), and those requiring greater effort were assigned a minus ('-'). A '-' symbol, assigned to a standard/solution, does not mean that the achievement of this pattern is impossible; rather, the 'work-arounds' necessary to achieve the pattern, using this standard/solution, are non-trivial.

### B.1 Java Spaces

Java Spaces supports a blocking-send through its `write` operation. However it does not support a non-blocking send, hence capability '2' was given a '-' in Table 1.

Java Spaces supports blocking-receive through its `read` or `take` operations, and supports non-blocking receive through its `notify` operation, hence capabilities '3' and '4' were assigned a '+' in Table 1.

Java Spaces, is time-decoupled, and is not time-coupled. Consequently capability '5' was assigned a '-' in Table 1.

Java Spaces supports space-decoupling over a channel, but does not support coupling one sender to one receiver, hence a '-' for capability '7' in Table 1.

Space-decoupling over a topic (e.g. publish-subscribe) is partially achieved if each 'subscriber' uses a `read` operation. Each receiver gets a copy of the message because the call to `read` does not remove the message from the space. Hopefully the message will be removed from the space before any receiver reads the same message twice. A simple, but not fail-safe 'work-around' to prevent this problem is to write the message to the space with a very short lease.

Java Spaces does not provide primitives for sending messages over an arbitrary set of templates, and we therefore rule out multicast. We rule out support for message joining because it does not support its `take`, or `read` operations over arbitrary sets of templates.

Java Spaces does not directly support responses, therefore patterns R1 – R6 of Table 1 were assigned a '-'.

### B.2 Axis

Axis is a SOAP engine that primarily uses HTTP as a transport. Like HTTP, it only offers a blocking-send, and a non-blocking-receive. Despite the fact that Axis can be configured to use JMS as a message transport service, it does not expose a non-blocking send or a blocking-receive in its API. Consequently non-blocking send and blocking receive were assigned a '-' in Table 1.

Axis, supports time-coupling but only when layered over a JMS implementation could it possibly support time-decoupling.

Axis directly supports space-coupling, but does not support space-decoupling. Despite the fact that JMS supports space-decoupling over channels and topics Axis does not expose constructs that allow users to exploit either of these features. Consequently, in Table 1, items '8' and '9' were assigned '-'.

Axis provides no direct support for multicast, or for message joining.

Axis supports many form of acknowledgement, hence it was well represented in the list of items of Table 1 related to responses. Nevertheless, preprocess acknowledgement (R1) is not supported. A ‘work-around’ solution would require forking off a thread in the server to process the message while sending a receipt acknowledgement in the response from the main thread. Non-blocking receive of responses is not possible without using callbacks, hence it is assigned ‘-’ in Table 1.

### B.3 CORBA

CORBA supports a blocking-send because the CORBA client blocks on remote object calls, at least until the request has reached the ORB. It supports non-blocking-receive because the remote object servicing requests never makes an explicit request to wait for an incoming request, this gets managed by the ORB. Nevertheless, CORBA provides no direct support for a non-blocking-send or a blocking-receive operation.

CORBA traditionally offers a time-coupled means of interacting, and using what it refers to as an ‘asynchronous’ style it provides direct support for time-decoupled interactions.

CORBA’s naming service is the primary way to address remote objects. The naming service maps a name to one remote object, as opposed to one of many, hence CORBA directly supports space-coupling. CORBA allows clients to obtain remote object references using Interoperable Object Group Reference (IOGR). This sort of remote object reference refers to one of many object implementations, and therefore CORBA supports space-decoupling over a channel. CORBA also has support for publish-subscribe, but achieving this style of interaction is not as straightforward as it should be, and therefore we consider that it only partially supports this (see Table 1).

CORBA does not directly support multicast or message joining hence we gave it ‘-’ for M1 and M2 of Table 1.

CORBA, like Axis would require thread forking techniques to provide the requestor with an acknowledgement before the request gets processed, therefore we gave response pattern R1 a ‘-’ in Table 1. Otherwise CORBA has the best representation of any of the solutions or standards evaluated for supporting the various forms of response, and that is reflected in Table 1.

### B.4 Java Message Service

The JMS standard directly supports blocking-send, blocking-receive, and non-blocking receive. However, it does not directly support non-blocking send. Nevertheless, most implementations of JMS can be configured with a sender, and middleware service on the same machine. The message is passed into the middleware service and then is put over the network without the sender needing to wait. Hence we assign JMS a ‘+/-’ for item ‘2’ in Table 1.

JMS, being a MOM driven standard, natively supports time-decoupling but not time-coupling. Hence a ‘-’ for item ‘5’.

JMS supports both forms of space-decoupling (channel and topic), but not space-coupling. Consequently item ‘7’ in Table 1 was assigned a ‘-’.

JMS, however does not support either of the multicast/join patterns.

JMS is not a request-response driven standard, but despite this it supports *preprocess* acknowledgements (R1) directly via session acknowledgements. It supports blocking-receive acknowledgements (R5) directly through its `QueueRequestor` and `TopicRequestor` classes. Post-process acknowledgements (R2) and post-process responses (R3) are supported through

the same classes. However, we deem this support only partial ('+/-') due to the need to parse for a return address and begin a new interaction at the responder (as discussed in Section 5).

## B.5 Websphere MQ

Websphere MQ is the MOM component of the Websphere suite, by IBM. Websphere MQ provides an implementation of the JMS standard and, of course, supports every pattern that JMS covers.

Additionally, Websphere MQ allows the configuration of one particular endpoint to exclusively receive messages off a channel. Therefore Websphere MQ fully supports space-coupling. Consequently item '7' in Table 1 was assigned a '+'.

## B.6 MSMQ

MSMQ is the MOM implementation by Microsoft. It provides MOM support to the BizTalk process application server and to the new Windows Communication Foundation.

MSMQ directly supports blocking-send, blocking-receive, and non-blocking receive. However, like the JMS, it does not directly support non-blocking send. Nevertheless the same work-around to achieve non-blocking send for JMS can be performed using MSMQ. Hence we assign MSMQ a '+/-' for item '2' in Table 1.

MSMQ, like most MOM solutions does not support time-coupling. Hence we assigned a '-' to items '5' and '6' in Table 1.

MSMQ has full support for space-decoupling over a channel but would require non trivial 'work-arounds' to achieve space-coupling. Therefore we assigned MSMQ a '-' for item '7' in Table 1.

With respect to *space-decoupling over a topic* MSMQ offers a `peek` operation in its API – allowing receiver endpoints to peek at messages in the queue. Using `peek` to support space-decoupling over a topic (or publish-subscribe) is a work-around, in much the same class as Java spaces. Therefore, it was assigned a '+/-' for item '9' in Table 1.

MSMQ, supports multicast directly but to our knowledge does not support multicast/join, or any of the request-response patterns.

## B.7 MPI

The Message Passing Interface, developed by a consortium of leading IT vendors and select members of the research community, was designed to enable parallel and distributed systems to exchange messages effectively. Using MPI, parallel applications are able to exploit processing on multiple CPUs for example, because the API is extremely efficient in its use of memory and the CPU. MPI fully supports all forms of thread (de-) coupling, providing explicit operations for blocking-send, non-blocking send, blocking-receive, and non-blocking receive – as is shown in Table 1.

MPI does not support time-decoupling – as shown in Table 1. MPI does not support space-decoupling over a channel. MPI is able to notify all members of a group with copies of the same message. This behaviour is strongly related to *space-decoupling over a topic*, however these groups are determined during build-time, or design-time. There seems to be limited support for joining a group at runtime, and no support for joining more than one group. We therefore rated MPI a '+/-' for *Space-decoupled (Topic)*.

MPI fully supports multicast, message joining and preprocess acknowledgement.

## C Composing the Dimensions Graphically - An Enumeration

To create a graphical representation of a coupling configuration the graphical notations associated with each of the nine coupling patterns presented in Section 3 can be used as a starting point. They are, more or less, obtained by “overlying” the notations for decoupling introduced in Section 3. As stated in Section 4, there are twenty-four possible combinations of these nine patterns, given that they represent points on different dimensions, or vectors. These graphical notations extend Message Sequence Charts [6].

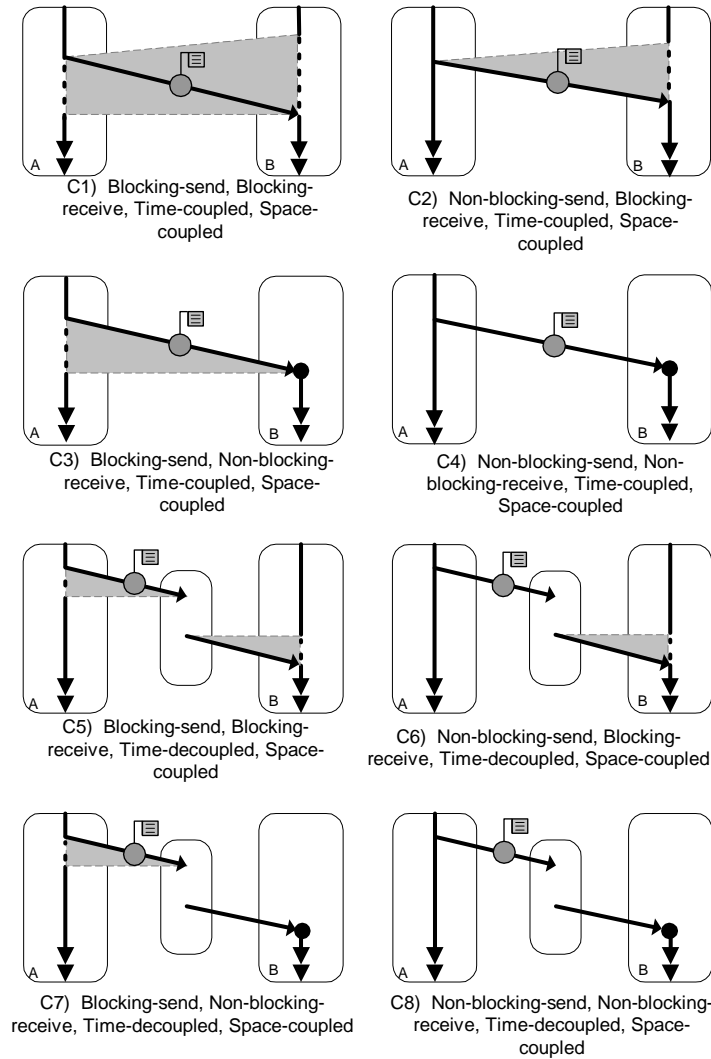

**Fig. 17.** Notations for the coupling integration configurations – space-coupled communication.

Figures 17, 18, and 19 present these combined notations.

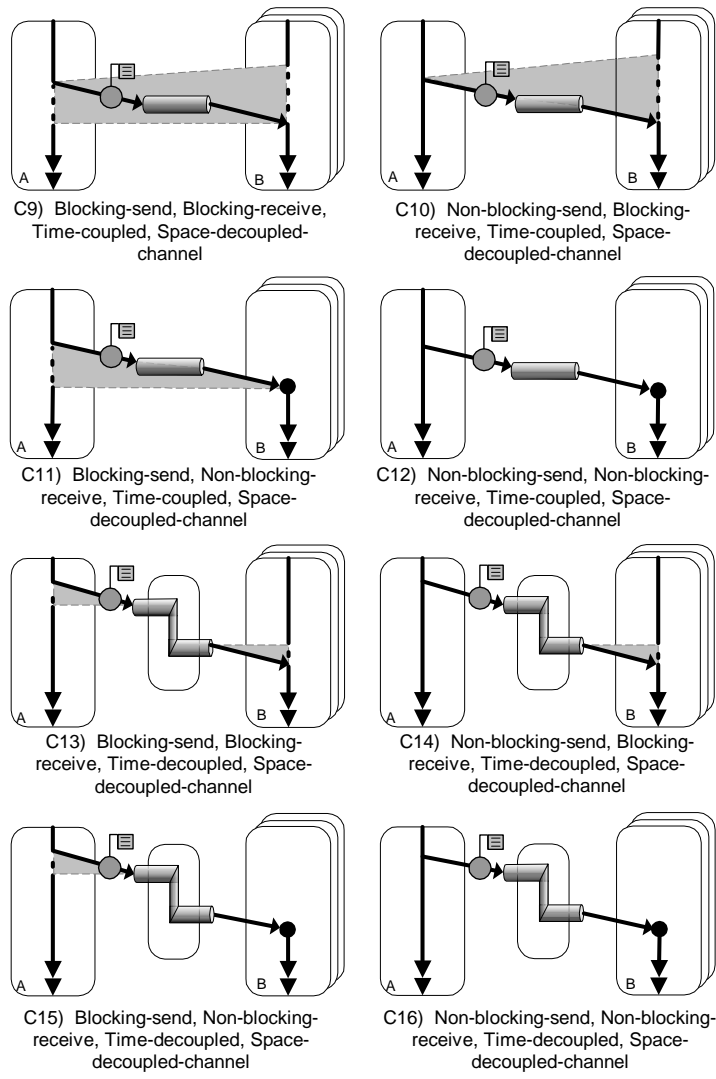
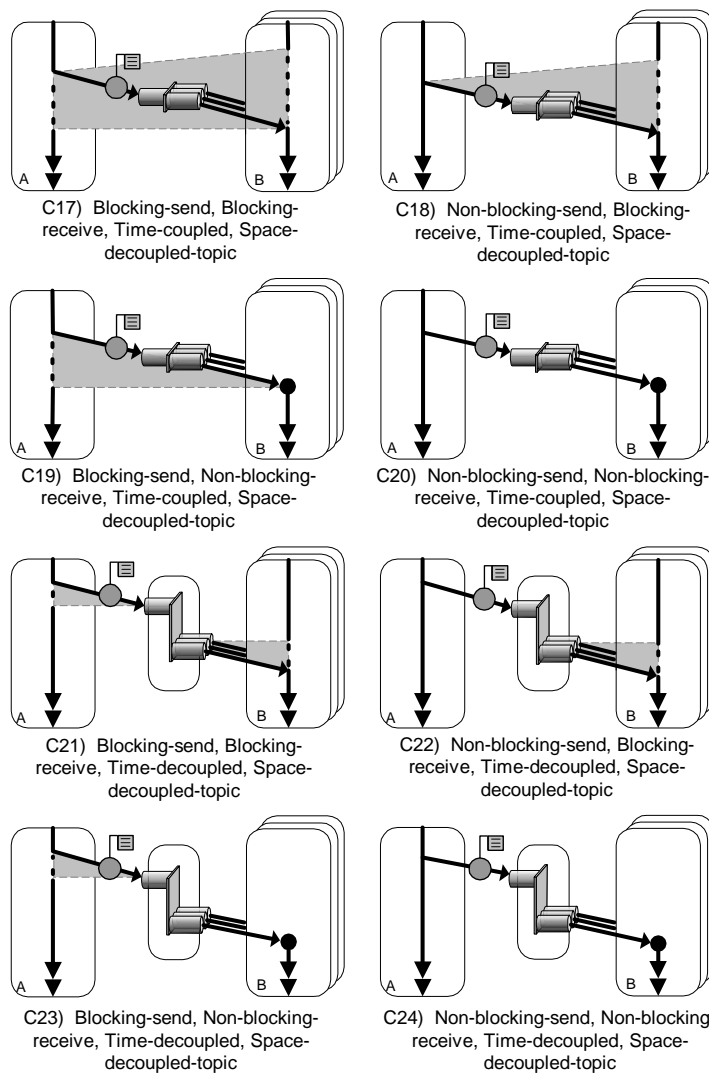

Fig. 18. Notations for the coupling integration configurations – Space-decoupled (Channel).



**Fig. 19.** Notations for the coupling integration configurations – Space-decoupled (Topic).

## D Extended CPNs and Simulation

Figure 20 presents a combination of a Blocking-send, and a Blocking-recv CPN - extended - to include a timeout. Either the sender or the receiver can timeout before the interaction has completed. Some new places, transitions and arcs were added (indicated in Grey) to perform timeouts. Note that the structure of the original CPNs (Figs. 1(b) and 3(b)) has been preserved. Nevertheless, we extended the colours **Thread** and **Msg** to **timed** (see 1 in Fig. 20). We also extended some arcs with timed expressions (see 2). The timed expression  $\text{msg@+m}$  adds  $m$  time units to the token  $\text{msg}$ . Variable  $m$  is declared as a random number between 4 and 7 (`colset M = int with 4..7`). This range of values was chosen for simulation purposes in such a way that the timeout may or may not occur. When the token  $\text{msg}$  is timed any transition it enables will not be allowed to fire until the current time equals  $m$ . We also changed two arcs to carry multiple tokens (see 3).

Change (3) was necessary because if a timeout occurred in the sender (removing a token from the place “*in progr*”) we need to clean up the incomplete interaction for the receiver (and vice versa). Put another way, if a timeout occurs during message transit for one endpoint the model must allow the other endpoint to timeout gracefully – preventing deadlock. Technically, using two tokens as shown by change (3) allows this.

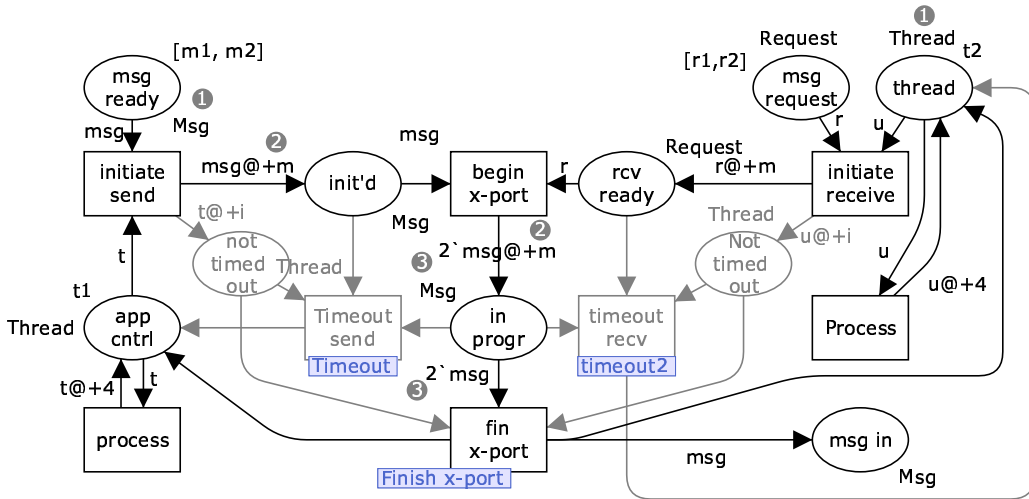

Fig. 20. Blocking-send, Blocking-recv with timeouts.

Using CPN tools we ran 40 simulations of this CPN. We found that there were three possible outcomes.

**Timed-out, no interactions** before the transition “*fin x-port*” had the time to fire – completing an interaction – both of the transitions “*Timeout send*” or “*Timeout recv*” fired.

**Timed-out, some completed interactions** at least one interaction completed such that transition “*fin x-port*” fired.

**All completed interactions** before any time-out transition could fire, all interactions were completed.

The delay to fire a transition (that progresses an interaction) was produced using a random value in the range of  $m$  (e.g.  $\text{msg@+m}$ ). This value influenced the interaction speed. The delay

to fire either of the time-out transitions was produced using a random value in the range of  $i$  (for our simulation runs  $i$  had a range of 15 .. 20). The value taken by  $i$  is used to establish the *timeout time* (e.g.  $t_0+i$ ). In our simulation runs we found that by increasing the interaction speed (i.e. decreasing the range of  $m$ ) we increased the number of *all completed interactions*. Conversely, by increasing the timeout speed we increased the number of *timed-out, no interactions*. These results are exactly in line with our intuition.

During simulation we found no outcome containing deadlocks or livelocks.

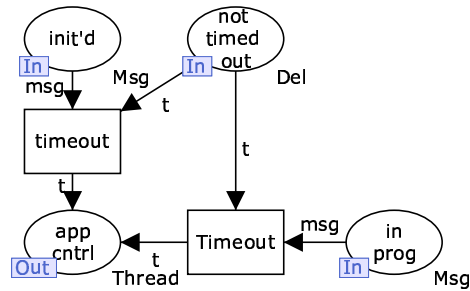

Fig. 21. Subnet decomposition “Timeout” of the transition “Timeout send” in Figure 20.

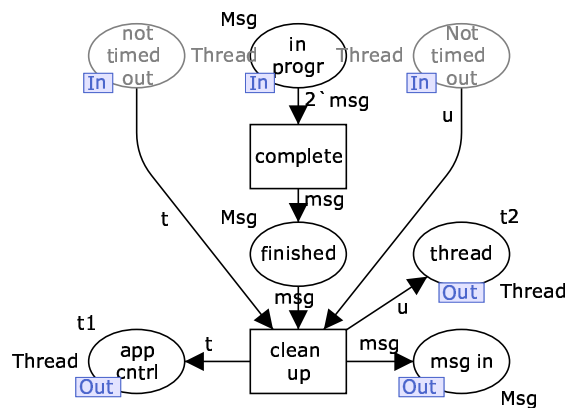

Fig. 22. Subnet decomposition “Finish x-port” of the transition “fin x-port” in Figure 20.